

A. PRODUCT NAME

FORM-A-DRAIN®

B. MANUFACTURER

CertainTeed Corporation
Pipe & Plastics Group
P.O. Box 860
Valley Forge, PA 19482

C. DESCRIPTION

C.1 SCOPE/REFERENCE:

This specification covers requirements of FORM-A-DRAIN® manufactured by CertainTeed Corporation. FORM-A-DRAIN functions as a permanent foundation footing form system, a foundation drainage system and a sub-slab perimeter radon evacuation system. U.S. Patent # 5,120,162; 5,224,799; 5,466,092 and 5,474,400. Canadian Patent # 2,135,168.

ASTM F 891: (for load deflection and impact) *PVC Plastic Pipe Type PS 25*

ASTM F 405: (for flow characteristics) *Slotted Corrugated PE Tubing*

EPA 402-R-94-009: *Model Standards & Techniques for Control of Radon in New Buildings*

ICC-ES Legacy Report # 95-37.01

C.2 GENERAL:

CertainTeed FORM-A-DRAIN functions as a permanent foundation footing form system, a foundation drainage system and a sub-slab perimeter radon evacuation system. System components are manufactured from a high-strength thermoplastic compound. The system consists of 12' (3.66 m) long extruded drainage channels, called "lineals," with sizes of 2.25" by 4" (57 mm by 102 mm), 6" (57 mm by 152 mm), and 8" (57 mm by 203 mm), and 1.50" by 10" (38 mm by 254 mm). Lineals are manufactured as hollow rectangular tubes with a solid interme-

diated web which stiffens the section and creates upper and lower channels of equal size (no web in 4" height). Lineals have slots in the exterior vertical face to allow the entrance of ground water. Water travels through the system to outlet fittings which provide the connection of FORM-A-DRAIN to an approved drainage disposal area. System components include: lineals, couplings, 90° & 45° corners, vertical "L"s & "T"s, drain outlets, spacer straps and grade stakes.

D. TECHNICAL

D.1 MATERIALS:

All lineals shall be made from an acceptable rigid PVC compound such that the finished product meets the minimum Youngs Modulus = 320,000 psi, Specific Gravity = 1.4, and minimum Allowable Yield Stress = 5,500 psi. Color shall be gray. Lineals are also available with adhered geotextile filter fabric for use when required by local codes.

D.2 APPROVALS:

FORM-A-DRAIN is covered by ICC ES Legacy Report #95-37.01 renewed every two years.

D.3 DIMENSIONS:

Lineals - corner squareness shall be 90° +/- 1/2°; radii tolerances are +/- .062"; all cut lengths = 12' +/- 1/2"; saw cuts per lineal foot = 12 1.5" X .090".

D.4 JOINTS:

Couplings and corners are manufactured for assembly by inserting the end of a lineal into the coupling or corner, without mechanical or solvent fastening

D.5 QUALITY CONTROL:

Quality control program covers material, performance requirements and marking. Product dimensions

shall be checked at start-up and periodically thereafter. All material is to be free from defects in materials and workmanship. Minor cracks may be field repaired in accordance with manufacturer's instructions.

E. INSTALLATION

Refer to CertainTeed literature #40-95-04, Installation Guide, for complete installation instructions.

F. SUGGESTED SOURCE OF SUPPLY

For nearest dealer location contact:
CertainTeed Corporation
Pipe & Plastics Group
Valley Forge, PA
1-800-233-8990
(610) 341-7940 fax
www.certainteed.com

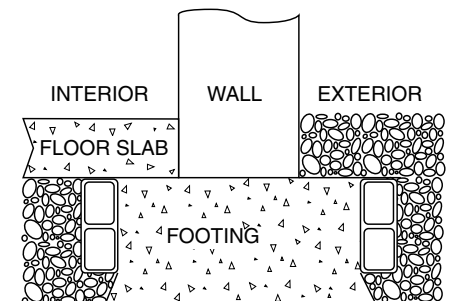

HOW THE FORM-A-DRAIN SYSTEM WORKS

The FORM-A-DRAIN system consists of lineal sections installed as the foundation footing forms. Upon completion of the concrete pour, the system stays permanently in place and performs the function of a foundation drainage system. It is also an effective method of reducing radon, since it is a sub-slab perimeter system that forms a complete loop around the foundation.

DIMENSIONS (SOME DIMENSIONS ARE ESTIMATES)

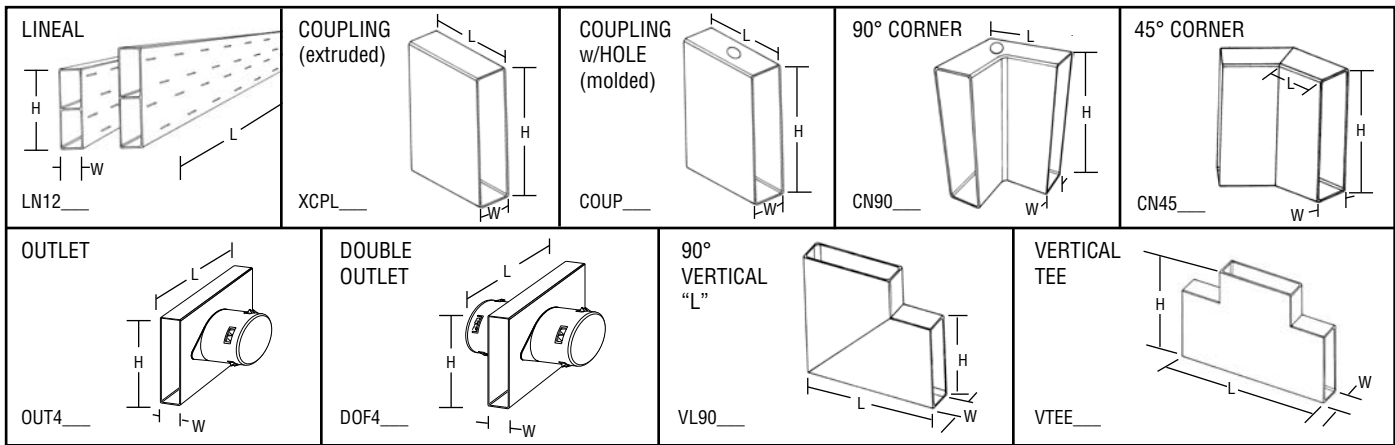

PART #	SIZE	DESCRIPTION	H	W	L
LN124	4	LINEAL*	4.0	2.25	12.0 ft
LN126	6	LINEAL*	6.0	2.25	12.0 ft
LN128	8	LINEAL*	8.0	2.25	12.0 ft
LN1210	10	LINEAL*	10.0	1.50	12.0 ft
XCPL4	4	COUPLING	4.17	2.41	6.00
XCPL6	6	COUPLING**	6.20	2.44	6.00
XCPL8	8	COUPLING**	8.23	2.48	6.00
XCPL10	10	COUPLING**	10.24	1.74	6.00
COUP6	6	COUPLING W/HOLE	6.27	2.49	5.75
COUP8	8	COUPLING W/HOLE	8.26	2.49	5.75
COUP10	10	COUPLING W/HOLE	10.28	1.78	5.75
CN904	4	90° CORNER	4.25	2.47	4.44
CN906	6	90° CORNER	6.27	2.49	5.28
CN908	8	90° CORNER	8.30	2.56	5.88
CN9010	10	90° CORNER	10.28	1.78	5.28
CN454	4	45° CORNER	4.17	2.41	2.41
CN456	6	45° CORNER	6.20	2.44	2.65
CN458	8	45° CORNER	8.23	2.48	2.64
CN4510	10	45° CORNER	10.24	1.74	2.02
OUT44	4	OUTLET	4.17	2.41	8.50
OUT46	6	OUTLET	6.20	2.44	10.00
OUT48	8	OUTLET	8.23	2.48	10.00
OUT410	10	OUTLET	10.24	1.74	10.00
DOF46	6	DOUBLE OUTLET	6.20	2.44	10.00
DOF48	8	DOUBLE OUTLET	8.23	2.48	10.00
DOF410	10	DOUBLE OUTLET	10.24	1.74	10.00
VL904	4	90° VERTICAL "L"	4.17	2.41	6.24
VL906	6	90° VERTICAL "L"	6.20	2.44	8.25
VL908	8	90° VERTICAL "L"	8.23	2.48	10.28
VL9010	10	90° VERTICAL "L"	10.24	1.74	12.19
VTEE6	6	VERTICAL "T"	9.06	2.44	10.25
VTEE8	8	VERTICAL "T"	11.11	2.48	12.25
VTEE10	10	VERTICAL "T"	12.99	1.74	14.25

* Lineals with fabric have the same dimensions as lineals.

** Also available as XSTK__ in 3-foot lengths to couple gaps up to 2.5 feet long.

All dimensions are in inches (except where shown), and are subject to normal manufacturing tolerances.

ASK ABOUT OUR OTHER CERTAINTeED PRODUCTS AND SYSTEMS:

EXTERIOR: ROOFING • SIDING • WINDOWS • FENCE • DECKING • RAILING • MILLWORK • FOUNDATIONS • PIPE
INTERIOR: INSULATION • WALLS • CEILINGS

CertainTeed Corportaion
 P.O.Box 860
 Valley Forge, PA 19482

Professional: 800-233-8990
 Fax: 610-341-7940
www.certainteed.com

