

EverNew®

Composite Railing Systems

STEP-BY-STEP

INSTALLATION INSTRUCTIONS FOR

SPECTRUM™ AND EVERNEW® 20 COMPOSITE RAILING

Virtually maintenance free | 20-year warranty

EverNew® Spectrum™ and EverNew® 20 Railing systems are designed to work with a number of different decking materials and surfaces. Before initiating any project, obtain a copy of your local building codes and understand them thoroughly. Local building code requirements will always supersede any and all suggested procedures and measurements in the following installation guideline.

Note: For more detailed instructions visit us online at www.certainteed.com

HELPFUL HINTS

Read these instructions thoroughly before beginning the assembly.

- Use carbide-tipped multi-purpose blade for cutting (minimum of 40 tooth blade recommended).
- Do not lay components on abrasive surfaces.
- If any components are missing or defective, please call us at: **800-380-5323**.

CertainTeed

IMPORTANT:

ALWAYS WEAR SAFETY GLASSES WHEN CUTTING AND DRILLING RAILING PRODUCTS.

BEFORE YOU BEGIN

TOOLS REQUIRED

- Miter Saw
- Power Drill and Bits
- No. 2 Square Head Driver
- Level
- Square
- Tape Measure
- Pencil
- Safety Glasses and equipment as identified by tool manufacturers

OPTIONAL TOOLS

- Jigsaw/Coping Saw
- Utility Knife
- File
- Chalk Line
- Silicone Caulk and Caulk Gun
- Angle Finder

TABLE OF CONTENTS

Post Installation	2
Spectrum Installation	5
EverNew 20 Installation	9

STORAGE AND HANDLING

Spectrum and EverNew 20 Composite Railing components should be stored on a dry, flat surface. Do not store in an area where excessive heat buildup can occur, such as on an asphalt surface covered by a tarp. Spectrum and EverNew 20 should be properly supported. Do not stack Spectrum and EverNew 20 more than 4 skids high. Individual Spectrum and EverNew 20 components may weigh more than wood, so take this into account before lifting or moving Spectrum and EverNew 20 Composite Railing.

Spectrum and EverNew 20 Composite Railing do not produce respirable dust when cut or fastened, but you should always wear eye protection and safety equipment when working with any wood product. For more information about the safety of Spectrum and EverNew 20 Composite Railing, consult the Material Safety Data Sheet (MSDS).

EXPOSURE TO WEATHER

Exposure to sunlight and water will not adversely affect the appearance of Spectrum and EverNew 20 Composite Railing. Normal weathering should be expected.

RAILING INSTALLATION

POST INSTALLATION

Determine where the railing posts will be positioned by using a scaled drawing of your project. For proper aesthetics, divide the perimeter dimensions evenly so that posts are spaced equally. To optimize post placement, additional joists or alternative locations may be required.

Spectrum and EverNew 20 guardrail systems should only be secured to code compliant posts. Securing a guardrail to another structure (i.e. building) is not recommended (Figure 1).

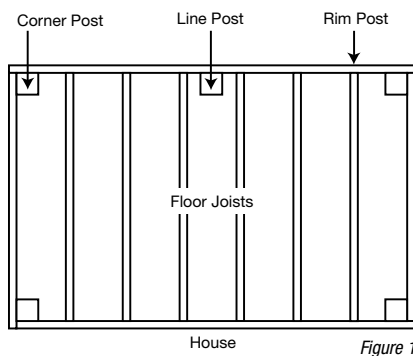

Note: The inside measurement between posts cannot exceed 96" for 8' section and 72" for 6' section.

Post Sleeve over wood post

Use the post sleeve method to install railing directly to a wooden 4" x 4" deck post. This is ideal for new deck construction methods that attach the rim joist directly to the 4" x 4" deck support posts, where wood 4" x 4" deck support posts extend through the deck serving as rail posts (Figure 2), or in those code compliant applications where the use of existing 4" x 4" wooden rail posts is desired.

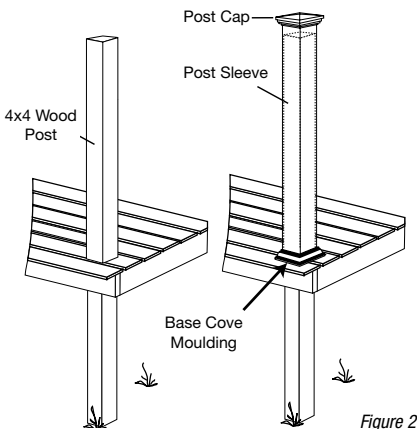

1. Ensure 4" x 4" wooden posts are code compliant and, where possible, spaced equally for the best-looking application.
2. Determine the desired height of post sleeve. Typically, the height is no less than 2" above the top of the finished railing system. This ensures the proper placement of the post caps that slide down over the top of the post sleeve.
3. Cut the post sleeve to the desired height.
4. The wood post should be approximately 1" shorter than the height of the post sleeve. Cut wood posts as necessary.
5. After decking is installed, slide post sleeve over the wood 4" x 4" post (Figure 2).

Post Sleeve Mount with wood insert (kits sold separately; item# 73081800)

Use the Post Sleeve Mount to install post sleeves directly onto the deck or porch surface. Post Sleeve mounts are available for concrete or wood/composite surfaces. When installing a post sleeve mount on a concrete surface, the support system is anchored into the concrete. When installed on a wood or composite deck, the support system is installed after the deck surface has been attached. Follow these guidelines to complete the post installation:

For Concrete: (Figure 3)

1. Determine the desired location(s) and finished height of the post sleeve from the deck surface.

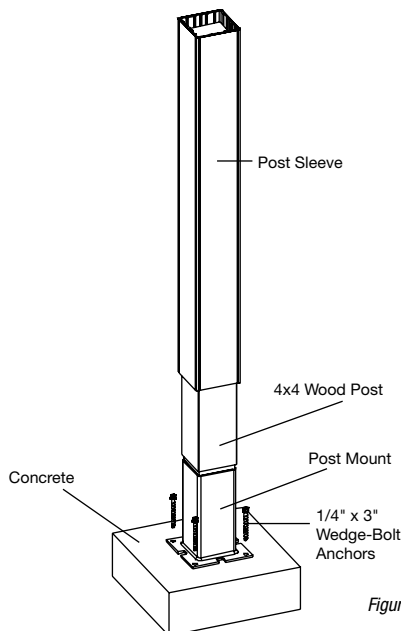

2. Trim the post sleeve to the desired length.
3. Ensure the treated 4" x 4" (generally 3.5" x 3.5" actual) wood post is structurally sound and code compliant.
4. Trim the length of the 4" x 4" wood post. The wood post length is typically 1-2" shorter than the post sleeve length.
5. The base of the mount should be positioned a minimum of 3" on center from the edge of the concrete pad. Use the base of the mount as a template and mark the four corner holes for the concrete Wedge-Bolt™ Anchors (included in kit).
6. Drill the marked holes using a 1/4" masonry drill bit. Drill the holes into the concrete base to a depth of at least 1/2" deeper than the length of the 1/4" x 3" Wedge-Bolt Anchors. Blow the hole clean of dust and debris (Figure 4).

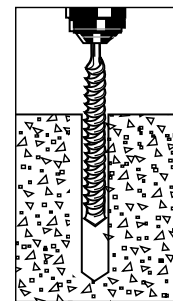

Figure 4

7. Locate the mount by aligning the mount corner holes over the drilled holes.
8. Insert the trimmed end of the 4" x 4" wood post into the mount. Ensure that the post is plumb and true.
9. If necessary, place a shim under the mount to make the post plumb and true.

RAILING INSTALLATION

10. Insert the four concrete Wedge-Bolt Anchors into the corner holes of the mount. Begin tightening the Wedge-Bolt Anchor by rotating clockwise and applying pressure in toward the base. This will engage the first few threads as the Wedge-Bolt Anchor begins to advance. Continue to tighten until the head of the Wedge-Bolt Anchor is firmly seated against the post mount (Figure 5). Repeat for the remaining Wedge-Bolt Anchors.

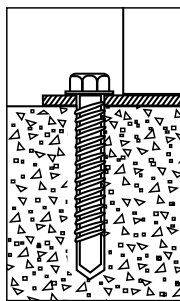

Figure 5

11. Slide the post sleeve over the 4" x 4" treated wood post until it contacts the base of the mount.

For Wood:

1. Determine the desired location(s) and finished height of the post sleeve from the deck surface.
2. The thickness of the wood/composite deck and reinforcement boards underneath the deck should be a minimum of 4" (two treated and structurally sound 2" x 8" lumber under the deck board, Figure 6). Fasten the reinforcement boards with 3" stainless steel fasteners as shown (Figure 7).

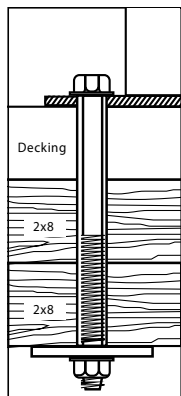

Figure 6

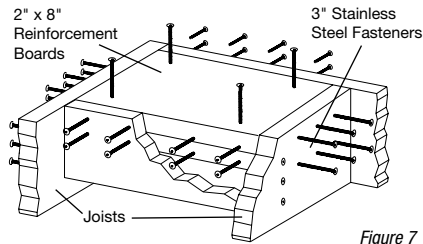

Figure 7

3. Trim the post sleeve to the desired length.
4. Ensure the treated 4" x 4" (generally 3.5" x 3.5" actual) wood post is structurally sound and code compliant.
5. Trim the length of the 4" x 4" wood post. The wood post length is typically 1-2" shorter than the post sleeve length.
6. Use the base of the mount as a template and mark the four corner holes on the deck surface. Mark inside square of bracket on deck surface.
7. Drill four 3/8" holes at the marked locations, drilling through the deck board and the reinforcement boards. Drill a 3/8" drainage hole in square through deck board and reinforcement boards for drainage.
8. Locate the mount by aligning the mount corner holes over the drilled holes.
9. Insert the trimmed end of the 4" x 4" wood post into the mount. Ensure that the post is plumb and true.
10. If necessary, place a shim under the mount to make the post plumb and true.
11. Insert the 5/16" x 5" galvanized hex bolts into the mount holes and the drilled holes. (Galvanized bolts and nuts not included)
12. Fasten the four bolts underneath the reinforcement boards with the 5/16" Fender washer (included in kit) and 5/16" galvanized hex nuts (Figure 8).
13. Slide the post sleeve over the 4" x 4" treated wood post until it contacts the base of the mount.

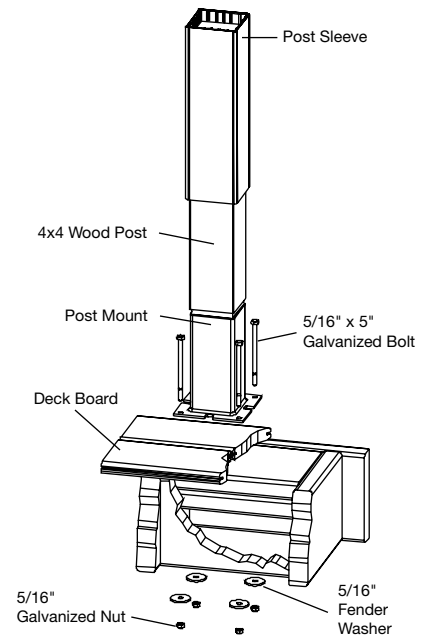

Figure 8

RAILING INSTALLATION

INSTALLING THE COMPOSITE POST SLEEVE

Prior to installation consult building code requirements for proper post installation. Local building codes supersede any and all recommendations in the following guide. Before installing the Composite Post Sleeve, review the installation instructions of the railing system planned for the project.

THE COMPOSITE POST SLEEVE IS A NON-LOAD BEARING POST AND SHOULD NOT BE USED AS A STRUCTURAL SUPPORT OF ANY KIND.

The Composite Post Sleeve is designed to slide over a structurally sound 4" x 4" (3.5" x 3.5" actual) wood post. The wood post should be plumb and true prior to installing the Composite Post Sleeve. When fully installed the Composite Post Sleeve should sit flush on the walking surface and should not extend more than 1" above the top of the wood support post (Figure 9). Trim wood post as appropriate. Before attaching the guard rail to the Composite Post Sleeve, be sure to install the Base Cove Moulding/Trim as shown in Figure 10. The Guard Rail System should only be secured to code compliant posts. Securing the Guard Rail System to another structure (i.e. building) is not recommended.

BASE COVE MOULDING/TRIM CANNOT BE INSTALLED AFTER RAILING IS ATTACHED!

CODE CONSIDERATIONS

The Base Cove Moulding/Trim requires a minimum spacing of 3" between the walking surface and the lower subrail. Some building codes may require a spacing of less than 3". In these instances, the lower subrail mounting brackets will interfere with the Base Cove Moulding/Trim. The installer has two ways to overcome this situation: (1) Notch the Base Cove Moulding/Trim to allow the lower leg of the bracket to sit against the post, or (2) Do not use the Base Cove Moulding/Trim.

Figure 9

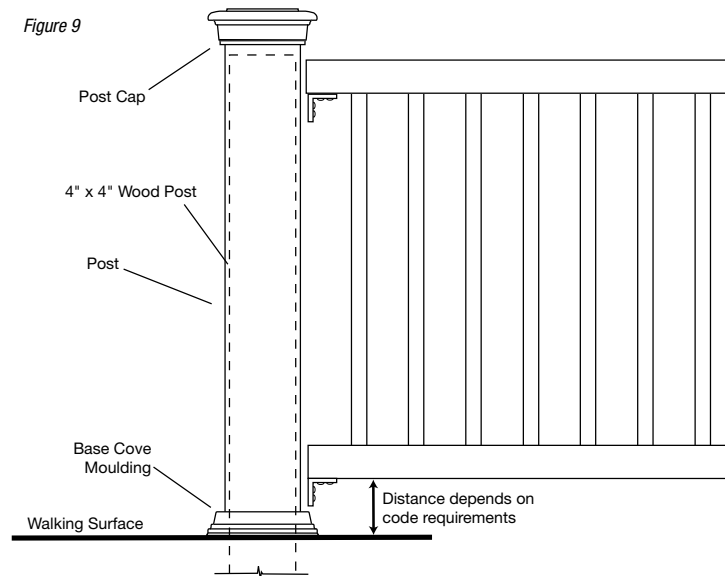
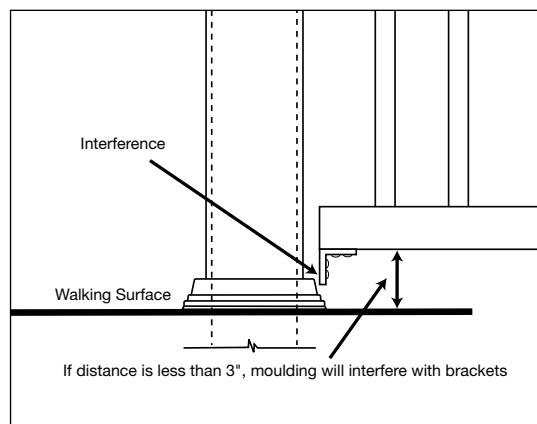

Figure 10



SPECTRUM COMPOSITE RAILING INSTALLATION

FLAT/LINE RAIL INSTALLATION

1. Measure the distance between properly installed, plumb posts.
2. Mark the top rail for the inside distance between the posts. The distance from the end of the rail to the first baluster slots should be equal on both ends of the rail. Ensure that the bracket screws will fasten into the top rail and that none fall into the routed baluster slots.

Note: Minimum distance from post to first baluster slot on top rail is 1-1/2".

3. Place the bottom rail next to the top rail so that the top and bottom baluster slots are aligned. Mark the bottom rail for the inside distance between the posts.
4. Cut the top and bottom rails to fit tightly between the posts.
5. Center the bottom bracket on the underside of the bottom rail (Figure 11). Inset the bottom bracket 1/16" from the end of the rail. Mark the three hole locations on the rail. Pre-drill 1/8" holes at the desired locations. Repeat for opposite end.

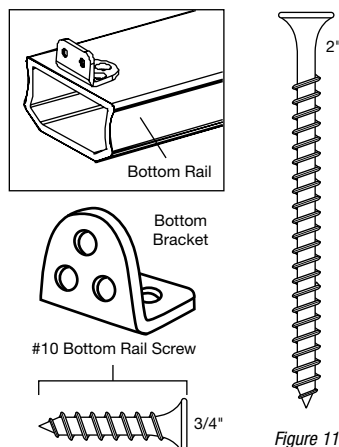

6. Secure the bottom bracket to the bottom rail using three #10 x 1" long screws. Repeat for opposite end. **DO NOT OVER-TIGHTEN SCREWS.**
7. Center the top bracket on the underside of the top rail (Figure 12). Inset the top bracket 1/16" from the end of the rail. Mark the three hole locations on the rail. Pre-drill 5/32" holes at the desired locations. Repeat for opposite end.
8. Secure the top bracket to the top rail using three #12 x 1" long screws. Repeat for opposite end. **DO NOT OVER-TIGHTEN SCREWS.**

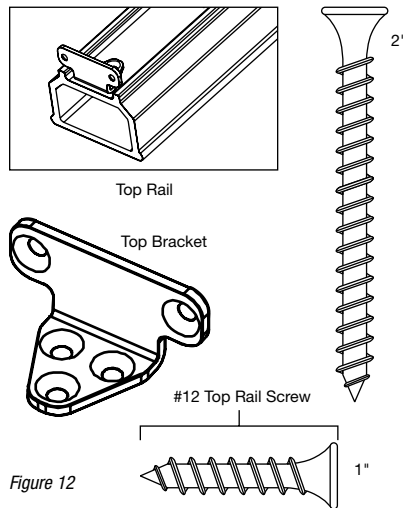

Figure 12

9. Ensure that the base cover moulding/trim is in place at the bottom of the posts (Figure 9).

10. Cut the crush block to the desired height (consult local building official for the proper spacing between the deck and the railing). Place crush block on the deck surface midway between the posts (Figure 16).
11. Place the bottom rail between the posts and on the crush block. Ensure that the bottom rail is level and that the ends of the rail are centered on the post.

12. Mark on the post the two bottom bracket hole locations. Pre-drill 5/32" holes at desired locations. Repeat for opposite end.
13. Secure the bottom rail to the post using two #10 x 2" long screws. Repeat for opposite end. **DO NOT OVER-TIGHTEN SCREWS.**

Note: A flexible shaft bit holder (not included) is helpful during this step.

14. Determine the desired baluster design (squared look, diamond look or a mixed pattern of the two) (Figure 13).
15. Ensure that all of the balusters are of equal length. Trim if necessary.
16. Fully engage the bottom baluster insert (Figure 14) into each baluster slot in the bottom rail. Orient the bottom baluster insert to achieve the desired look (Figure 13).
17. Fully engage a baluster over each bottom baluster insert.
18. Fully engage the top baluster insert (Figure 15) into each baluster slot in the top rail. Ensure that the top baluster insert is oriented the same as the corresponding bottom baluster insert.

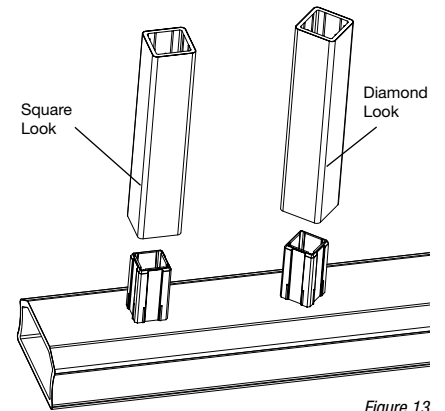

Figure 13

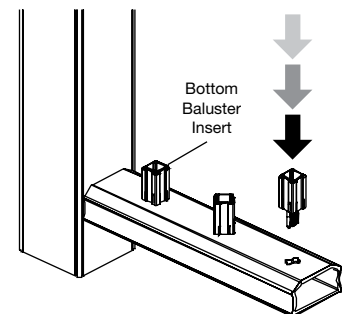

Figure 14

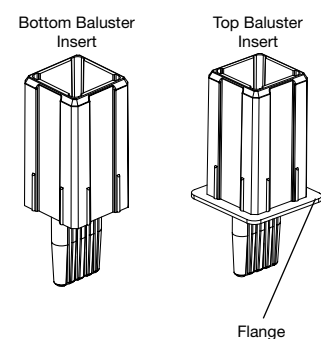

Figure 15

SPECTRUM COMPOSITE RAILING INSTALLATION

19. Place the top rail between the post and above the top end of the balusters (Figure 16). Starting at one end of the rail, reposition top end of the baluster to allow the top baluster insert to engage it. Repeat for each baluster.
20. Once all of the balusters are engaged, gently push down on the top rail until the bottom end of the balusters contacts the bottom rail (Figure 16). The flange of the top baluster insert should be tightly secured between baluster and the underside of the top rail.
21. Ensure that the top rail is level and that the rail ends are centered on each post.
22. Mark on the post the two top bracket hole locations. Predrill 5/32" holes at the desired locations. Repeat for opposite end.
23. Secure the top rail to the post using two #12 x 2" long screws. Repeat for opposite end. **DO NOT OVER-TIGHTEN SCREWS.**

Note: A flexible shaft bit holder (not included) is helpful during this step.

24. Using PVC cement, glue crush block to underside of bottom rail midway between the posts.
25. Mount and glue post caps after all rail section are installed.

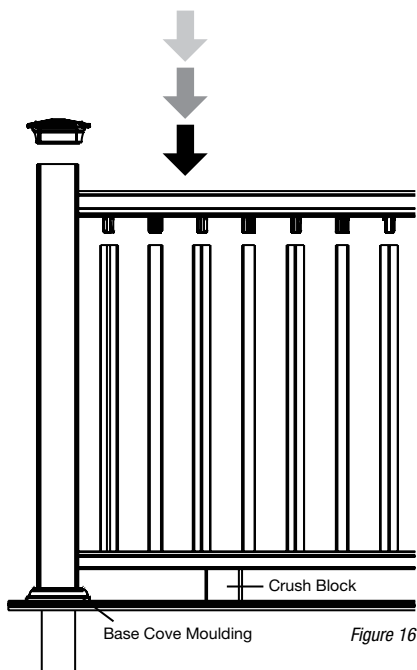

Figure 16

STAIR RAIL INSTALLATION (requires stair rail kit)

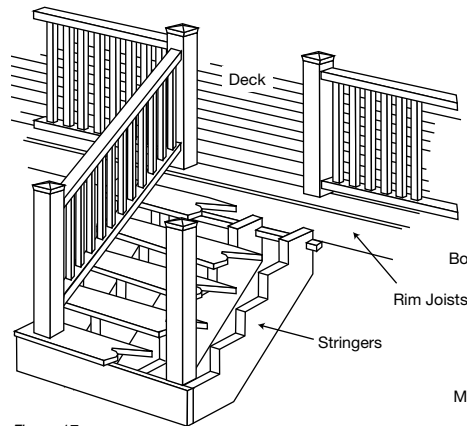

Figure 17

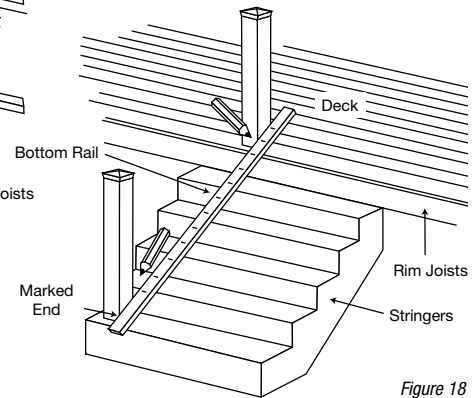

Figure 18

Note: The stair angle is a 32 degree angle which is equal to a 7" rise and an 11" run. Building codes are very specific on allowable angles and widths. It is very important to consult with your local building code officials and plan your stair layout accordingly. Ensure that you leave adequate space for graspable hand rail if applicable. "Dry fitting" intermediate post placement will result in easier and better-looking installations and may avoid placement of post mounting brackets in areas where screws cannot attach to the guardrail.

1. Position two line posts at top of stairway with the desired spacing and secure each post with the appropriate installation method (Figure 17).
2. Install the outside stringers just wider than the post's location. The posts mounted at the bottom of the stairs will be on the inside of the stringer and must line up directly with the posts at the top of the stairs.

Note: For stairs longer than six feet, it will be necessary to use multiple stair sections. The distance between posts, measured at an angle, should not exceed 70 inches. Ensure all posts are plumb prior to final mounting.

3. Lay bottom rail on stair with marked end at lower post. Center the rail between the posts so that the distance from the post to the first routed hole is equal on both ends. (Figure 18).

4. Mark angles on the bottom rail.
5. Cut the bottom rail to length. Ensure that the rail fits tightly between the posts.
6. Place the top rail next to the bottom rail with the marked ends together. Using the bottom rail as a guide, center the routed holes in the top rail with the routed holes in the bottom rail. Mark the cut lines on the top rail (Figure 19).
7. Cut the top rail to length.

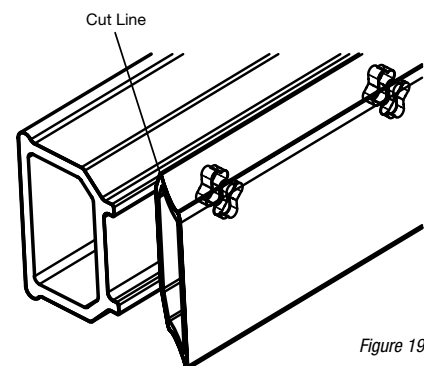

Figure 19

SPECTRUM COMPOSITE RAILING INSTALLATION

STAIR RAIL INSTALLATION (continued)

Figure 20

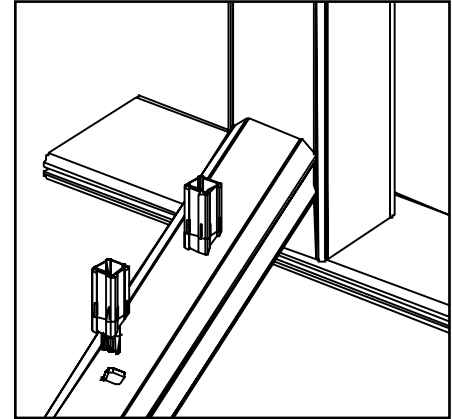
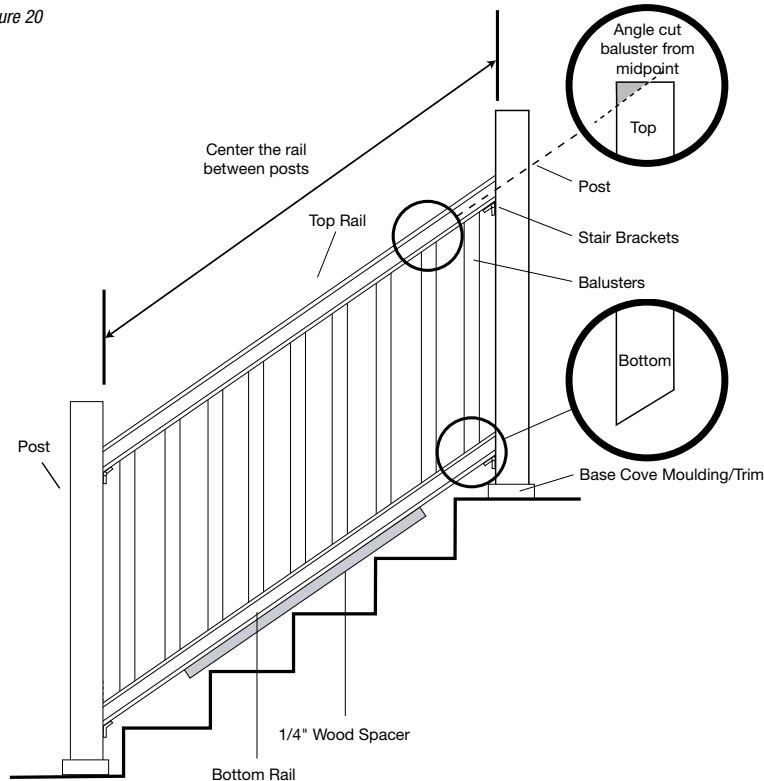

Figure 21

8. Ensure that the base cove moulding/trim is in place at the bottom of the posts (Figure 20).
9. Center the hinged bracket on the underside of the bottom rail. Inset the hinged bracket 1/16" from the end of the rail. Mark the three bracket hole locations on the rail. Pre-drill 5/32" hole at the desired locations. Repeat for opposite end.
10. Secure the hinged bracket to the bottom rail using three #12 x 1" long screws. Repeat for opposite end. **DO NOT OVERTIGHTEN SCREWS.**
- Note:** For easier access to securing the fasteners in a stair assembly, a hinge bracket with side wings (currently used for securing the top rail) may be substituted for the bottom hinge bracket without the side wings.
11. Repeat steps 8-9 for the top rail.
12. Lay the bottom rail, with the routed holes upward, onto a 1/4" wood spacer located between the posts (Figure 20). This provides the rail spacing between the rail and stair treads and helps to stabilize the setup.
13. Using the hinged bracket as a template, swing the unsecured leg of the bracket downward so that it touches the post. Mark the two hole locations on the post. Repeat for opposite end.
14. Remove the bottom rail from between the posts.
15. Pre-drill 5/32" holes at desired bracket hole locations.
16. Place bottom rail between the posts. Secure the bottom rail to the post using two #12 x 2" long screws. Repeat for opposite end. **DO NOT OVERTIGHTEN SCREWS.**
17. Fully engage the baluster inserts into the routed holes of the bottom rail (Figure 21).
18. Mark the stair angle on one end of each baluster to be used (Figure 20).
19. Cut the stair angle on one end of each baluster, cut the stair angle on half of the other end (Figure 20).
20. Fully insert the top ends of the balusters into the routed holes of the top rail. The angled cut of the baluster should be parallel with the length of the top rail (Figure 20).
21. Place the top rail and balusters on top of the baluster inserts. Locate each baluster so that the baluster insert is engaged inside of the baluster.
22. Gently push down on the top rail until the bottom end of the balusters contacts the bottom rail.
23. Ensure that the top rail ends are centered on each post.
24. Using the hinged bracket as a template, swing the unsecured leg of the bracket downward so that it touches the post. Mark the two hole locations on the post. Repeat for opposite end.
25. Slightly pull the top of the rail section toward the staircase to gain access to holes. Pre-drill 5/32" holes at desired locations. Repeat for opposite end.
26. Secure top rail to post using two #12 x 2" long screws. Repeat for opposite end. **DO NOT OVERTIGHTEN SCREWS.**

SPECTRUM COMPOSITE RAILING INSTALLATION

ANGLE RAIL INSTALLATION (angle bracket kit sold separately; used with Flat/Line Rail Kit)

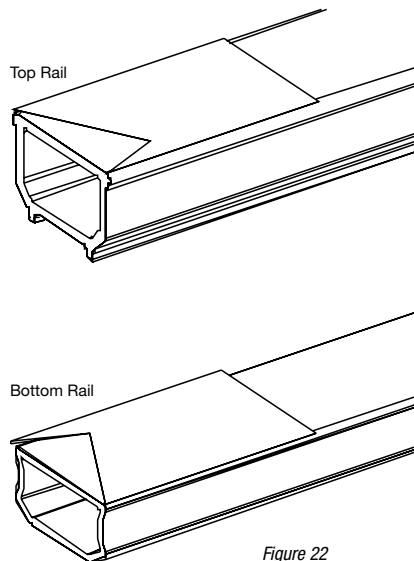

Figure 22

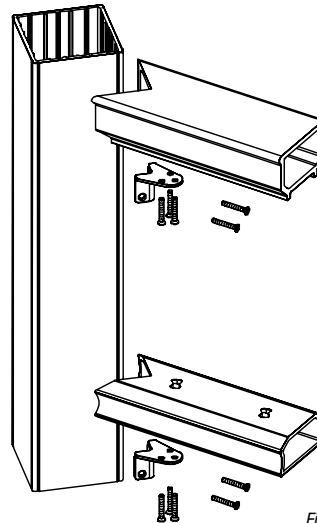

Figure 23

Rails up to 30 degrees may be mounted to the post face by using the In Line "L" Bracket (Figure 11 on page 5). Rails should be cut at the appropriate angle to fit tight against post. Cutting rails greater than 30 degrees will result in a rail that does not fully fit on post. Angles greater than 30 degrees require the use of the Angle Mount Bracket.

1. Determine the angle of your installation by using the supplied template (located on page 15 of this booklet).
2. Cut the template out along the appropriate marked lines. (You may want to photocopy the template as a backup prior to cutting).

3. Position the template on the non-routed flat side of the top rail. Mark the proper cutting angle (Figure 22).
4. Position the template on the non-routed bottom surface of the bottom rail (Figure 22). Mark the proper cutting angle. Template will be reversed from top rail.
5. Ensure baluster holes are equidistant from the end of rail to ensure proper vertical alignment.

Note: Minimum distance from post corner to first square baluster hole 1-1/2".

6. Make angle cuts in top and bottom rails.
7. Align the angled brackets with the 90 degree cut in the railing. Inset the bracket 1/16" from rails end. Mark the three screw hole locations on both rails. Repeat at opposite end. Pre-drill 1/8" holes at desired locations (Figure 23).
8. After fitting angles to posts, follow the Line Rail instructions (Steps 6 through 22) to complete the rail section installation.

EVERNEW 20 COMPOSITE RAILING INSTALLATION

FLAT/LINE RAIL INSTALLATION

Figure 24

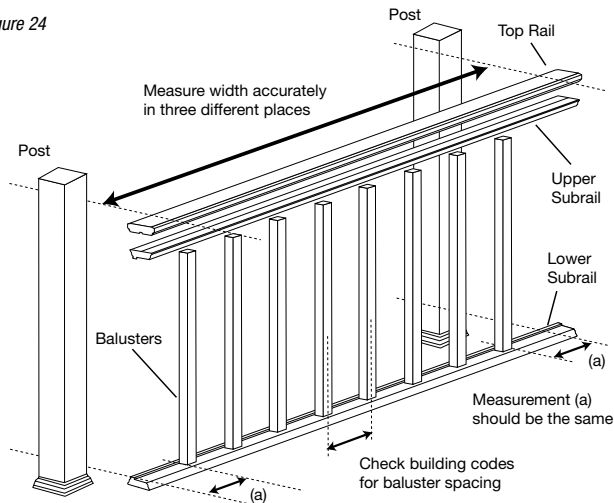
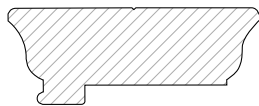
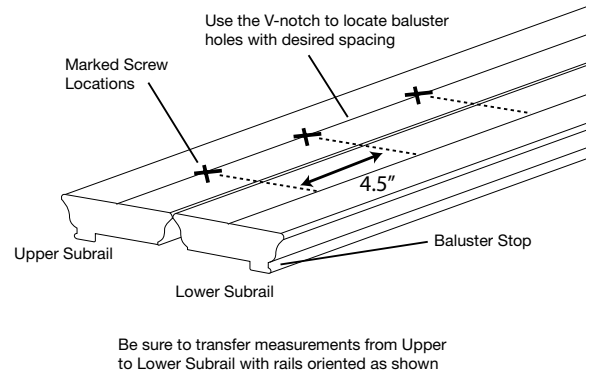

Figure 25



Two-Part System

1. Identify all hardware components:

- a. (4) In-Line Brackets (post to rail connections)
- b. (8) #10 – 3/4" long Phillip's head screws (bracket to lower subrail only)
- c. (8) # 10 – 1-3/8" long Phillip's head screws (bracket to top rail and upper subrail assembly only)
- d. (8) # 10 – 1-3/8" long Phillip's head screws (upper subrail to top rail)
- e. (17) # 10 – 2" long Phillip's head screws (bracket to post only)
- f. (42) # 10 – 1-3/4" long Phillip's head screws (rails to balusters only)
- g. (1) Phillip's head driver

2. Measure the distance between installed posts at various heights. Check to determine the distance does not vary more than 1/16" (Figure 24).

3. Trim the three rail components to fit between the posts, i.e., top rail, upper subrail and lower subrail. Cut should be square to ensure a good fit with the post.
4. Determine the spacing for balusters. For a full 8' guardrail length, the baluster spacing is 4.5" on center and equal spacing at both ends of the guardrail (3"). Typically, building codes require spacing between balusters less than 4".

Note: Don't position screws near the end of the rails, which is reserved for rail/post bracket installation (minimum distance = 2-1/4").

5. Mark the center location for each baluster on the upper subrail. Transfer these locations to the lower subrail by laying the lower subrail beside the upper subrail as shown in Figure 25.
6. Drill clearance holes using a 7/32" diameter drill bit for all pre-marked locations.
7. Drill 3/8" counter-bored holes from bottom side of lower subrail approximately 1/2" deep for all hole locations in the lower subrail (Figure 32). This step is optional if attempting to hide the screw heads.
8. Trim all 32" balusters to the desired length.
9. Using a 1/8" bit, drill holes that are 2" deep, centered in each end of the baluster
10. Place #10 – 1-3/4" long Phillip's screw into each of the counter-bored holes in the lower subrail.

11. Secure a baluster in each location of the lower subrail. In the two-part system, ensure balusters are against the baluster stop. **DO NOT OVER-TIGHTEN SCREWS.**
12. Secure the balusters in each corresponding location of the subrail using #10 – 1-3/4" long Phillip's screws. In the two-part system, ensure balusters are against the baluster stop. **DO NOT OVER-TIGHTEN SCREWS.**
13. Mark 8 hole locations equally spaced on the top surface of the subrail. Choose locations mid-point between the balusters.
14. Drill using a 7/32" diameter drill bit through the subrail.
15. Drill 3/8" counter-bored holes from the baluster side of the upper subrail, approximately 1/2" deep for the eight hole locations in the upper subrail. This step is optional if attempting to hide the screw heads (Figure 26).
16. Center the top rail on the upper subrail. The baluster screw heads will help you with proper alignment.
17. Using the holes created in Step 14, mark hole positions on the top rail.
18. Using a 1/8" bit, drill holes that are 3/4" deep into the top rail.
19. Secure the top rail to the assembly using 8 #10 – 1-3/8" long Phillip's screws. **DO NOT OVER-TIGHTEN SCREWS.**

EVERNEW 20 COMPOSITE RAILING INSTALLATION

FLAT/LINE RAIL INSTALLATION (continued)

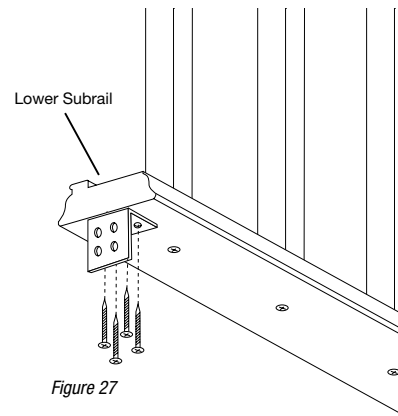
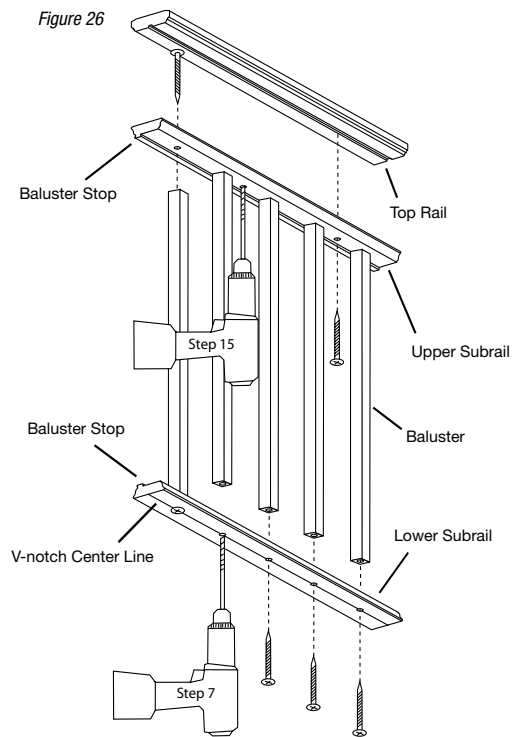

Drill 3/8" counter bore holes 1/2" deep prior to fastening in steps 12 and 19 (this step is not required, but if you want to install the crush block directly under the baluster, you must counter bore those holes)

Note: If you are using the Composite Post Sleeve Moulding/Trim, it must be installed on the post before continuing the rail installation. It cannot be installed after the railing is attached to the post! Refer to "Installing the Composite Post Sleeve" on page 4.

20. Using mounting bracket as a template, center the bracket on the bottom surface of the lower subrail and 1/16" from the end of the lower subrail (Figure 27). This promotes a tight fit when securing the rail section to the post.
21. Mark the four hole locations on the lower subrail and pre-drill using a 1/8" drill bit, approximately 1/2" deep.

22. Attach the bracket to the lower subrail using 4 -#10 - 3/4" long screws. DO NOT OVER-TIGHTEN SCREWS

Note: If longer screws are used, the screws may be exposed on the top surface of the lower subrail.

23. Repeat Steps 20 – 22 for the other end of the bottom guardrail.
24. Repeat Steps 20 – 23 for top rail and upper subrail assembly by centering the bracket on the bottom surface of the top rail and upper subrail assembly. Use 4 #10 – 1-3/8" long screws to secure the bracket to the top rail and upper subrail assembly.

25. Cut two crush blocks from excess baluster materials. Check building code requirements for maximum spacing between the walking surface and the lower subrail; typically the maximum heights range between 2" – 4".
26. Space the crush blocks equidistant between the posts (Figure 28).
27. Center the assembled section between the posts while laying the assembled section onto the crush blocks.
28. Ensure the top rail and lower subrail are level.

EVERNEW 20 COMPOSITE RAILING INSTALLATION

FLAT/LINE RAIL INSTALLATION (continued)

Figure 28

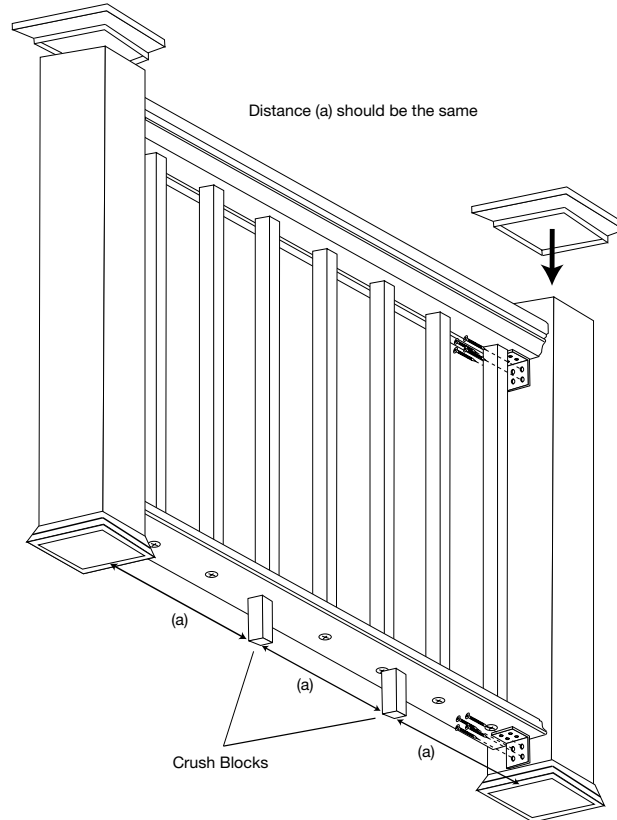

29. Mark the screw locations on the posts for both ends of the lower subrail using the mounting brackets as templates.
30. Drill holes using a 1/8" drill bit at marked screw locations approximately 2" deep. If needed, remove assembled section for ease of drilling.
31. Attach brackets to the post with 4 – 2" long screws at each end of the lower subrail. DO NOT OVER-TIGHTEN SCREWS.

32. Center the top rail and upper subrail on the post. Mark hole locations on the posts using the brackets as a template.
33. Drill holes using a 1/8" drill bit at marked screw locations approximately 2" deep. If needed, slightly pull the assembled section inward toward the deck to accommodate drilling into the post.
34. Attach the rail bracket to the post with 4 – 2" long screws at each end of the upper subrail. DO NOT OVER-TIGHTEN SCREWS.

35. Repeat Steps 33 and 34 for the other upper subrail bracket.
36. Apply adhesive to the crush blocks and secure to the lower subrail.
37. Secure post caps using adhesive on the inside corners of the post cap.
38. Push caps firmly onto the post. Wipe excess adhesive off the post sleeve.

EVERNEW 20 COMPOSITE RAILING INSTALLATION

STAIR SYSTEM INSTALLATION

Figure 29

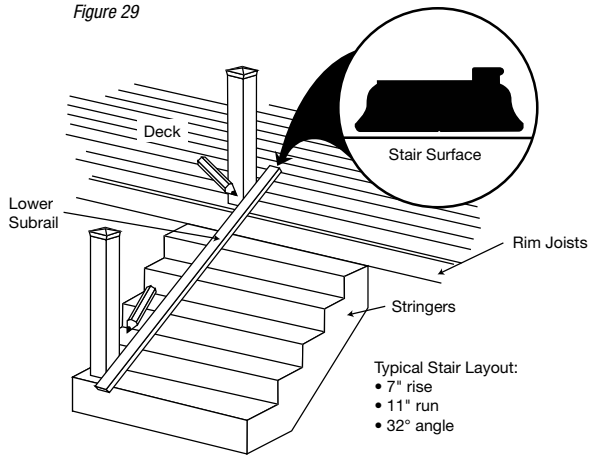
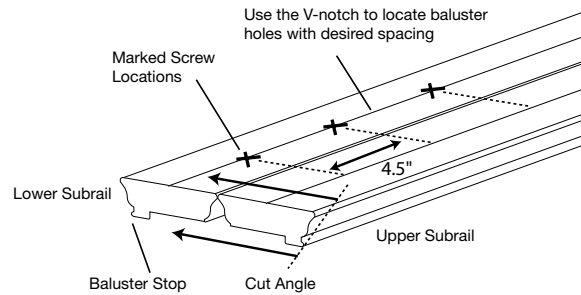

Figure 30



Be sure to transfer measurements from Subrail to Bottom Rail with rails oriented as shown

1. Identify all hardware components:
 - a. (4) Hinged Brackets (post to rail connections)
 - b. (8) #10 – 3/4" long Phillip's head screws (bracket to lower subrail only)
 - c. (8) #10 – 1-3/8" long Phillip's head screws (bracket to upper subrail only)
 - d. (8) #10 – 1-3/8" long Phillip's head screws (upper subrail to top rail)
 - e. (17) #10 – 2" long Phillip's head screws (bracket to post only)
 - f. (42) #10 – 1-3/4" long Phillip's head screws (rails to balusters only)
 - g. (1) Phillip's head driver
2. Measure the distance between installed posts at various heights. Check to determine the distance does not vary more than 1/16".
3. Lay lower subrail on stairs. Mark angle on rail (Figure 29).
4. Cut the lower subrail to the marked angle and to proper length. Check fit at both ends.
5. Using the same angle, cut the upper subrail and top rail to length and check fit.
6. Determine the spacing for balusters. The baluster spacing is 4.5" on center and equal spacing at the guardrail ends. Typically, building codes require spacing between balusters less than 4".
7. Mark the location for each baluster on the top surface of the upper subrail. Use the V-notch on the two-part system. Transfer the baluster locations from the upper subrail to the top surface of the lower subrail. Make sure the distance from the baluster stop can accommodate the location of the baluster on the two-part system.

Note: Don't position screws near the end of the rails, which is reserved for rail/post bracket installation (minimum distance = 2-1/4").

Note: The hole locations should be the same on the top surface of the upper and lower subrails with respect to the end of the rail and baluster stop (Figure 30).
8. Drill clearance holes at the appropriate angle through the upper subrail using a 7/32" diameter drill bit for all hole locations.
9. Drill clearance holes at the appropriate angle through the lower subrail using a 7/32" diameter drill bit for all hole locations.
10. Drill 3/8" counter-bored holes on the bottom surface of the lower subrail 1/2" deep for all hole locations. This step is optional if attempting to hide the head of the screws (Figure 31).
11. Trim all 32" balusters to the desired length at the appropriate angle.
12. Drill 1/8" holes that are 2" long, centered in each end of the baluster. The drilled holes should follow the center line of the baluster.
13. Place #10 – 1-3/4" long Phillip's screws into each counter-bored hole in the lower subrail.
14. Secure a baluster in each location of the lower subrail. On the two-part system, be sure the baluster rests firmly against the raised baluster stop on the lower subrail.
15. Secure the balusters in each corresponding location on the upper subrail. On the two-part system, be sure the baluster rests firmly against the raised baluster stop on the upper subrail.
16. Mark 8 hole locations equally spaced along the top surface of the upper subrail. Use the V-notch of the two-part system for a center line. The marked locations should be near mid-point between balusters. After drilling, the hole should be at the midpoint between balusters on the bottom surface of the upper subrail.
17. Drill clearance holes using a 7/32" diameter drill bit in the upper subrail at the appropriate angle for the staircase.

EVERNEW 20 COMPOSITE RAILING INSTALLATION

STAIR SYSTEM INSTALLATION (continued)

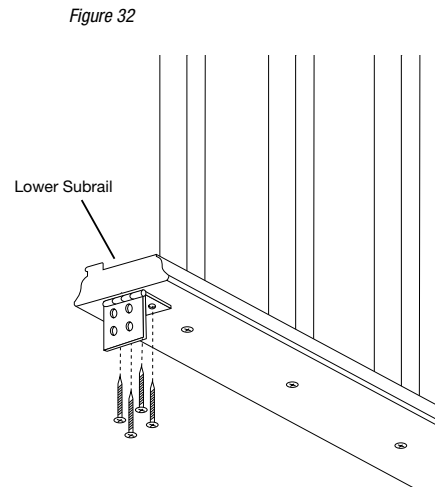
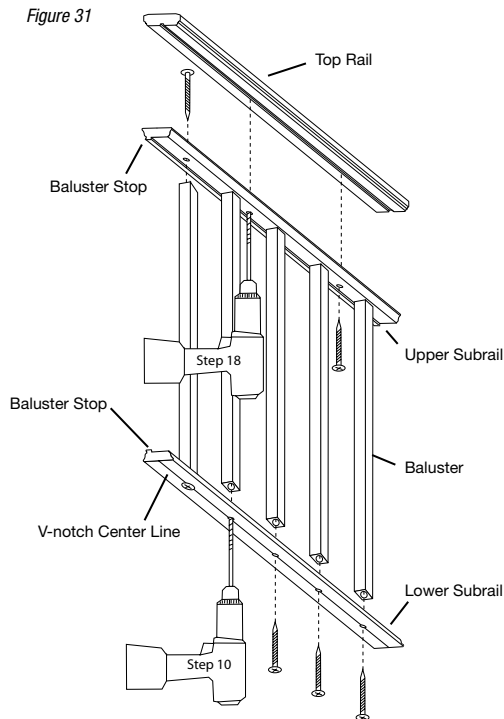

Drill 3/8" counter bore holes 1/2" deep prior to fastening in steps 14 and 22 (this step is not required, but if you want to install the crush block directly under the baluster, you must counter bore those holes)

18. Drill 3/8" counter-bored holes on the bottom surface of the upper subrail 1/2" deep for all hole locations. This step is optional if attempting to hide the head of the screws (Figure 31).
19. Place the top rail on the subrail/baluster assembly (Figure 31).
20. Mark hole positions on the bottom of the top rail.
21. Using a 1/8" bit, drill holes at the appropriate angle that are 1" deep into the top rail.

22. Secure the top rail to the assembly using 8 #10 – 1-3/8" long Phillip's screws. DO NOT OVER-TIGHTEN SCREWS.

Note: If you are using the Composite Post Sleeve Moulding/Trim, it must be installed on the post before continuing the rail installation. It cannot be installed after the railing is attached to the post! Refer to "Installing the Composite Post Sleeve" on page 4.

23. Using hinged bracket as a template, place the bracket on the bottom surface of the lower subrail 1/16" from the rail edge. The 1/16" spacing promotes a tight fit when securing the rail to the post (Figure 32).

24. Mark the four hole locations on the lower subrail and pre-drill a 3/4" deep hole using a 1/8" drill bit.

25. Attach the bracket to the lower subrail using 4 #10 – 3/4" long screws. DO NOT OVER-TIGHTEN SCREWS.

26. Repeat Steps 23 – 25 for the other end of the lower subrail.

27. Repeat Steps 23 – 26 for upper subrail/top rail assembly by placing the bracket on the bottom surface of the upper subrail.

EVERNEW 20 COMPOSITE RAILING INSTALLATION

STAIR SYSTEM INSTALLATION (continued)

Figure 33

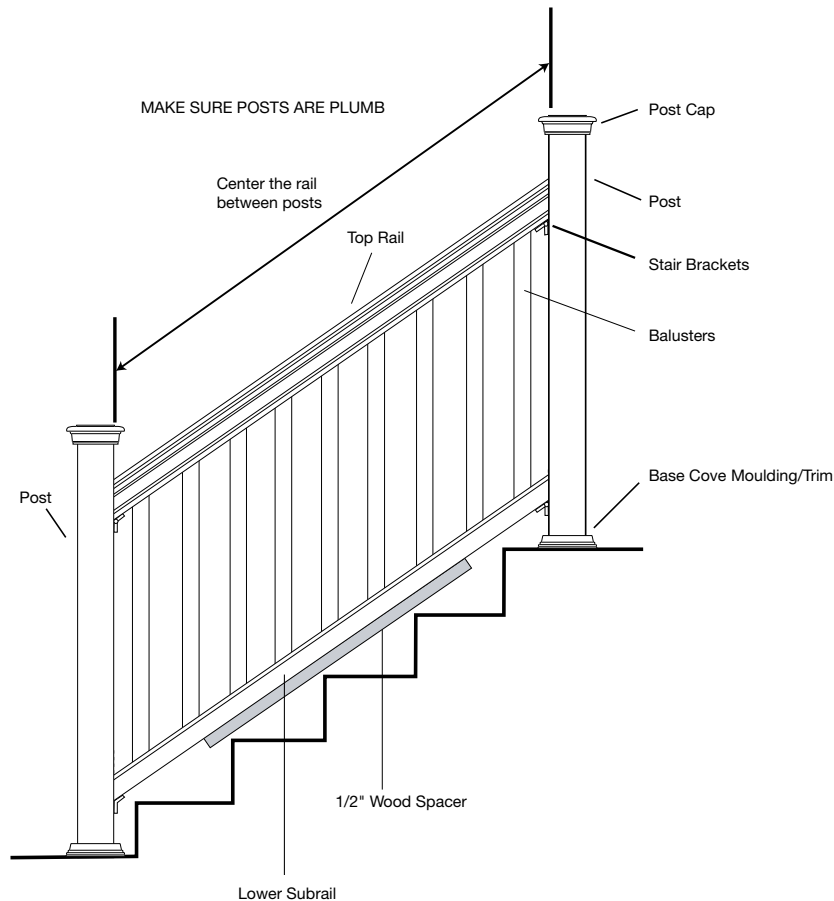

28. Lay the assembled section on a 1/2" thick wood spacer to facilitate the installation (Figure 33).
29. Center the assembled section between the posts. Check building code requirements for maximum spacing for staircase between the stairs and guardrail; typically it is limited to a 6" sphere.
30. Mark the screw locations of the lower subrail on the posts using the brackets as templates.

31. Drill holes using a 1/8" drill bit at marked screw locations. If needed, remove assembled section for ease of drilling.
32. Attach lower subrail/post brackets to the posts with 4 #10- 2" long screws on each end of the guardrail. **DO NOT OVER-TIGHTEN SCREWS.**
33. Center the top rail on the post. Mark hole locations on the posts using the brackets as templates.
34. Drill holes using a 1/8" drill bit at marked screw locations. If needed, pull the assembled section towards the stairs for ease of drilling.

35. Attach top rail/post brackets to the posts with 4 #10 – 2" long screws on each end of guardrail. **DO NOT OVER-TIGHTEN SCREWS.**
36. Secure post caps using adhesive on the inside corners of the post cap and position the cap onto the post.
37. Push the caps firmly onto the post. Wipe excess adhesive off the post.

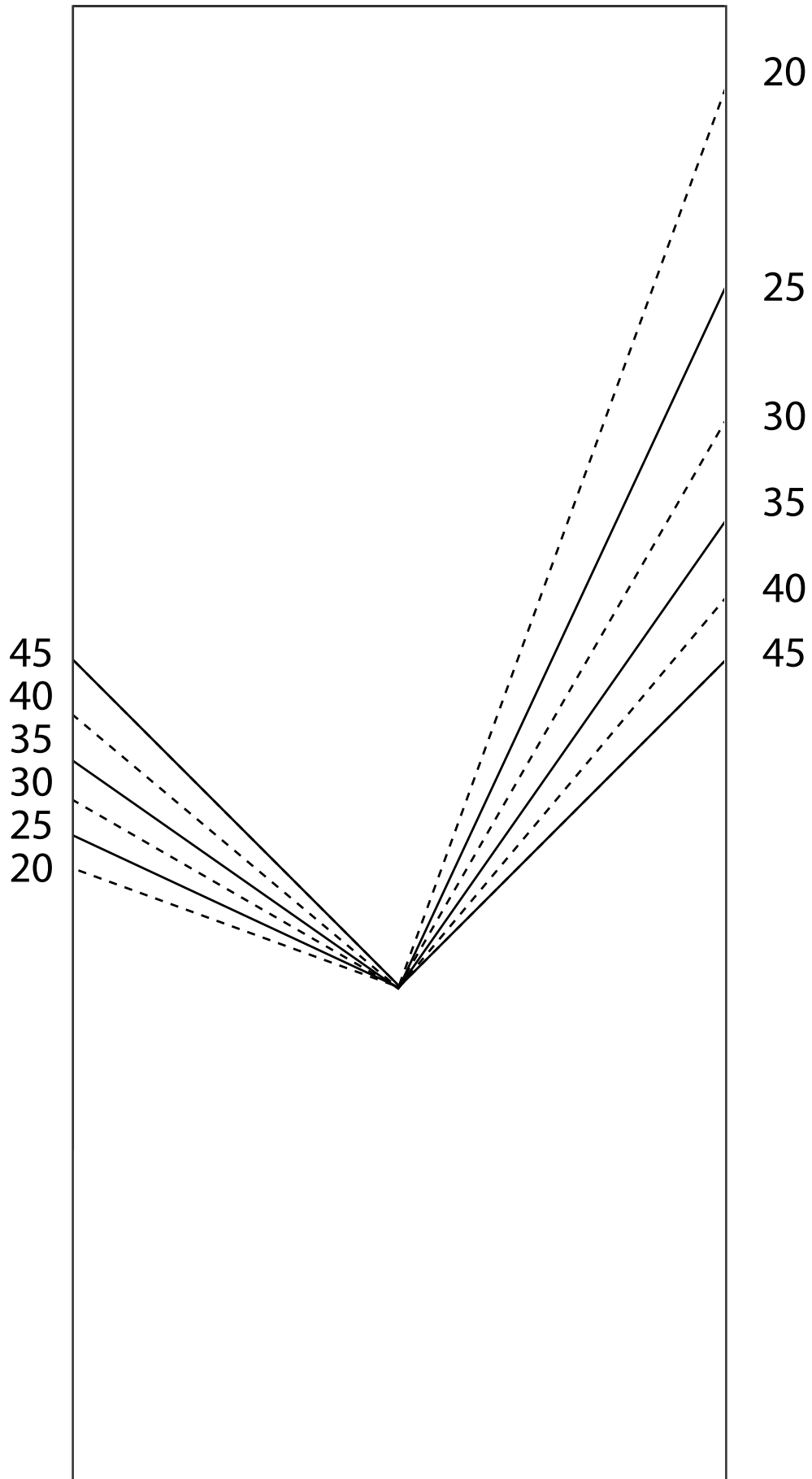

SPECTRUM ANGLE RAIL CUTTING TEMPLATE

Manufactured by Fiberon®
fiberon
The Decking Solutions Company

ASK ABOUT OUR OTHER CERTAINTEED PRODUCTS AND SYSTEMS:

EXTERIOR: ROOFING • SIDING • WINDOWS • FENCE • RAILING • TRIM • DECKING • FOUNDATIONS • PIPE
INTERIOR: INSULATION • GYPSUM • CEILINGS

CertainTeed Corporation
P.O. Box 860
Valley Forge, PA 19482

Professional: 800-233-8990
Consumer: 800-782-8777
www.certainteed.com

CertainTeed 