

These instructions describe and illustrate the steps involved in installing CertainTeed siding and trim. Their purpose is to provide detailed information and how-to tips that will simplify the installation process. CertainTeed shall not accept any liability or responsibility under its written warranty for failure caused by application that does not meet our minimum requirements for proper installation. These requirements are outlined throughout the *CertainTeed Installation Guide (CTS205)*. Any deviations from these requirements should be approved in writing by CertainTeed Corporation.

CedarBoards™ insulated siding will help even out wall surfaces. However, to minimize extremes in the peaks and valleys of uneven walls, you may have to repair the underlayment. Make sure the substrate is smooth and flat. If the surface is significantly uneven, apply 1/4" foam sheathing before installing CedarBoards siding.

Starter strips

Insulated siding is thicker than hollow vinyl siding. To accommodate the 1-1/4" thickness, we recommend that you use the CedarBoards starter strip.

When you can't use the CedarBoards starter strip, secure the siding panel with a combination of utility trim and J-channel. To do this, you will have to remove some of the foam backing and shim accessories to accommodate the thickness of the CedarBoards panel.

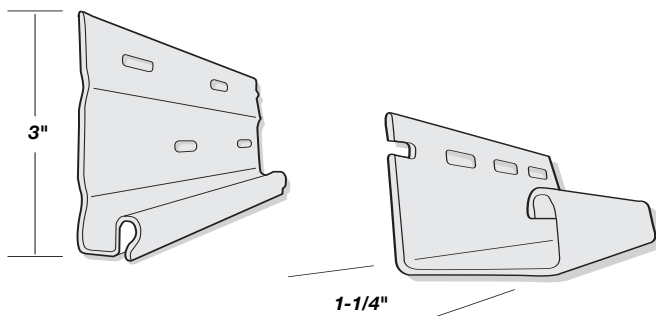

Fastening

Use 2" corrosion-resistant nails, and penetrate the wood substrate by at least 3/4".

The nail flange on insulated siding is typically 3/4" thick. Drive the nails until there is 1/16" between the nail head and the nail flange.

Center the nail in the nail slot and drive the nail straight in. Do not drive nails at an angle. Space nails 16" o.c.

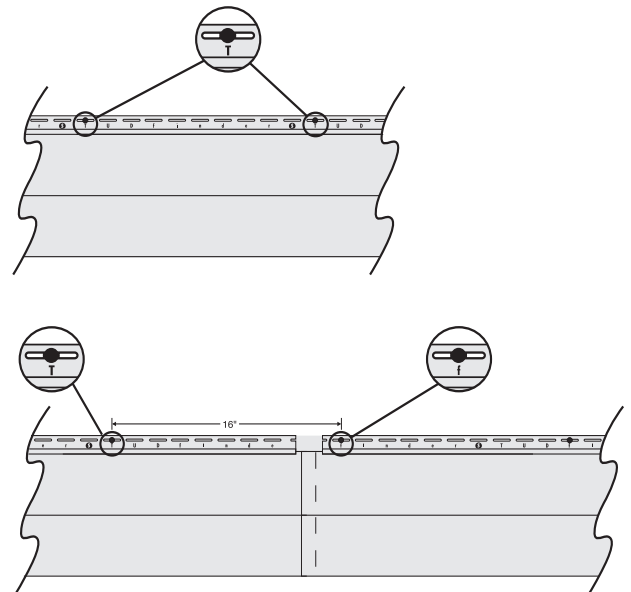

STUDfinder™ Installation

The STUDfinder™ Installation System combines precisely engineered nail slot locations with graphics to create a siding panel that is designed to help ensure quick, accurate and secure installation.

The nail slots are positioned 16" on center to allow for alignment with studs, with STUDfinder graphics centered directly under each nail slot.

Locate the first stud and fasten in the center of the nail slot. Ensure that nail/staple penetration is at least 3/4". Notice which STUDfinder letter appears below the slot.

Go to the next repeat of the letter to find the next stud. For example, if your first stud is at "T," so will the succeeding studs in 16" o.c. applications (every 10th slot). When installing CedarBoards XL panels on 16" centers, the succeeding studs are at every 8th slot.

When you apply the next panel, adjust the overlap, as necessary, to line up with studs and repeat the steps above.

Fitting into trim pieces

Around windows, doors, and other openings, use CedarBoards accessories. Insert the factory- or field-cut end of the siding panel into the accessories.

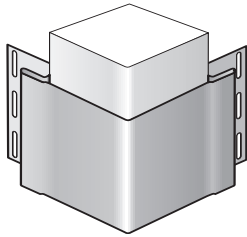

When the outside temperature is higher than 40° F, allow a 1/4" gap between the siding and the trim. When the temperature is less than 40° F, leave a 3/8" gap. For CedarBoards XL, allow a 3/8" gap between the siding and the trim when the outside temperature is above 40°F; 1/2" when the temperature is below 40°F.

All other accessories should be fitted with foam shims and fillers. These shims will ensure that the accessories are on the same plane as the panels.

To fit panels into non-CedarBoards accessories, remove 1-1/4" of additional foam from the ends of factory-cut panels. Remove 2" of foam from the ends of field-cut panels. Fit all non-CedarBoards accessories with foam shims and fillers.

NOTE: If you use two 1-1/4" J-channels to form an inside cornerpost, you do not have to use shims or remove foam from the siding panels.

Around windows and doors

Because insulated siding is thicker than hollow vinyl siding, windows, doors, and other openings may have to be built out to avoid looking recessed. Use wood shims and either aluminum trim coil or vinyl lineals to build out openings. In some cases, the foam backing in CedarBoards siding will create enough stiffness to span over or under a window without additional support.

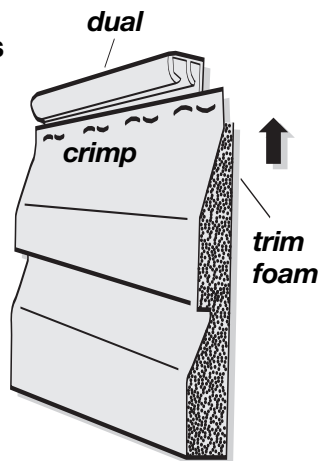

If you are using utility trim or dual undersill trim to secure the panel, shim the trim to accommodate the thickness of the siding panel. Remove the top 1" of the foam backing so the top of the panel fits into shimmed trim. Use a snap lock punch to raise tabs every 6" to lock the panels into the trim.

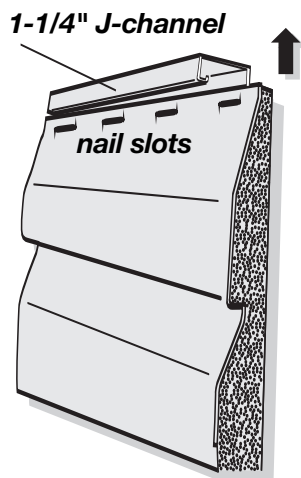

When you cut a siding panel to fit around an opening, use a nail slot punch to create additional nail slots. Fasten through these additional nail slots to secure the panel. Make sure the face of the J-channel or other trim will cover the nail slots.

Under soffit

Secure the last course of siding under the soffit with utility trim, dual undersill trim, or cornice receiver with cornice molding. You will have to create tabs and nail slots as described above. You will also have to shim the trim and remove the top 1" of the foam so the top of the panel fits into the trim.

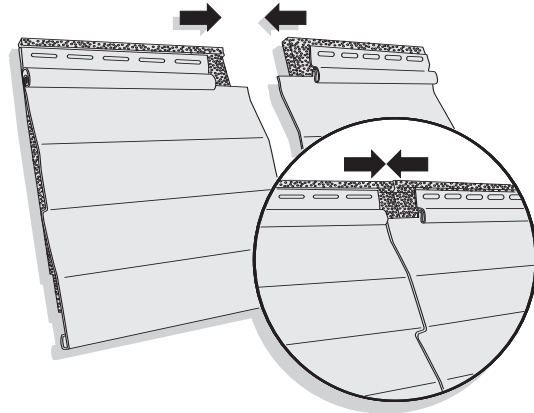

Overlapping panels

On factory-cut panels, the foam is set back from both ends of the panel. The adhesive begins 2" back from the end of the foam. To correctly overlap the panels, slip the vinyl edge of the bottom portion of the seam between the foam and the vinyl panel. Slide the panels together until the foam ends touch.

For CedarBoards XL, overlap the panels 1-1/4" to 1-3/4" at temperatures above 40°F; 1" to 1-1/4" when the temperature is below 40°F.

If you have any questions about installing this product, please call us at 1-800-233-8990.