

Installation Guide for FlintEdge Snap on Facing Reglet

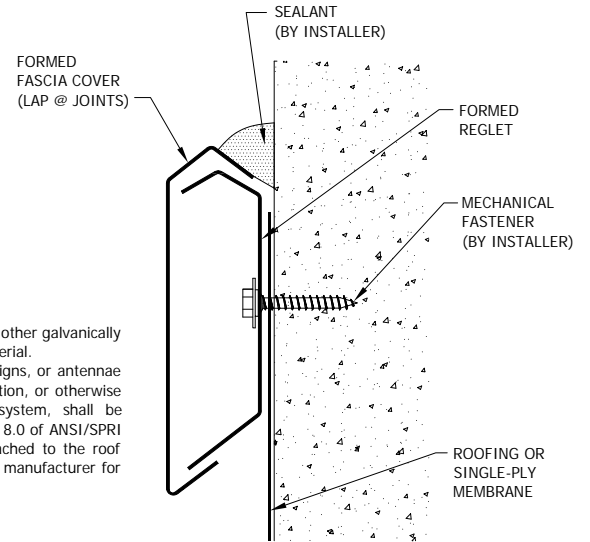

NOTES:

#1 - Isolate all metal parts from ACQ treated wood or other galvanically incompatible material with appropriate membrane material.
#2 - Appliance attachments, such as lightning rods, signs, or antennae that penetrate the water seal, induce a galvanic reaction, or otherwise compromise the effectiveness of the roof edge system, shall be eliminated or isolated to prevent problems per section 8.0 of ANSI/SPRI ES-1. Appliances should be isolated from or not attached to the roof edge system. Consult the lightning protection system manufacturer for specific attachment instructions.

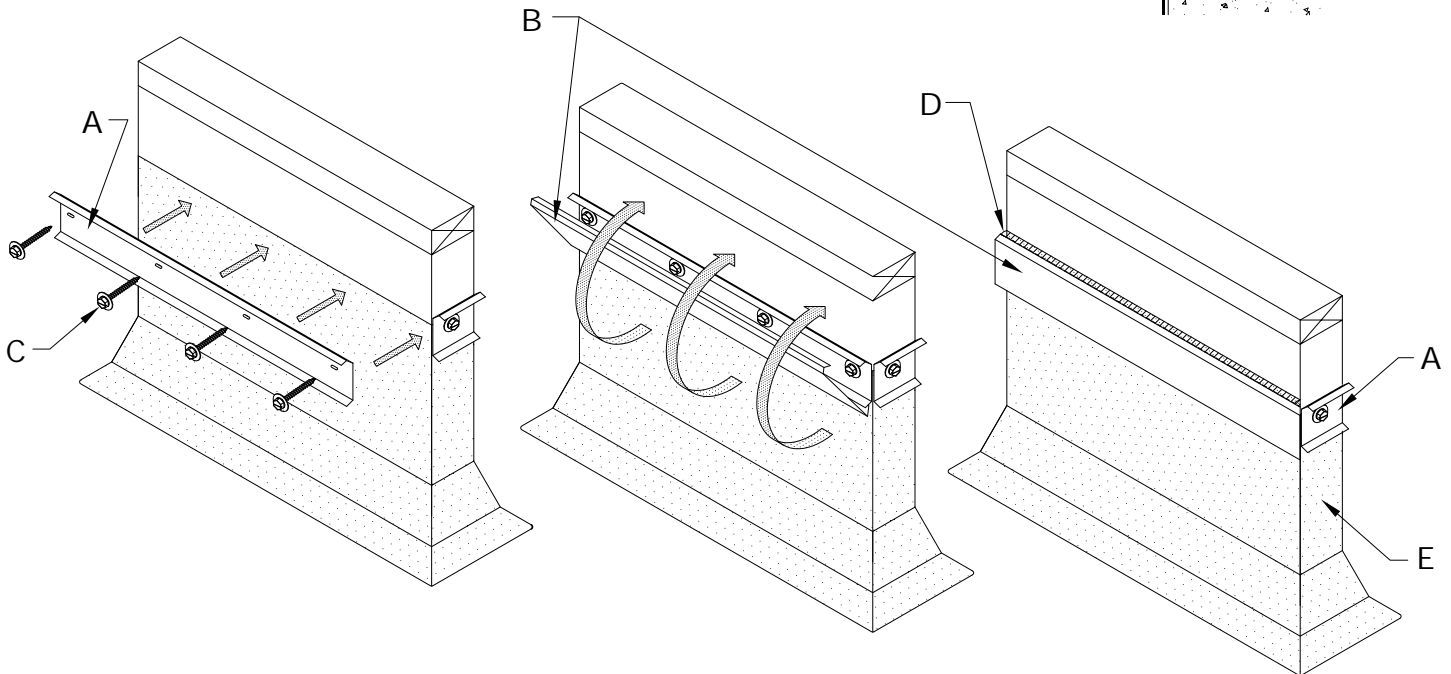

- A. Formed Reglet
10'-0" Lengths
- B. Formed Fascia Cover
10'-0" Lengths
- C. Mechanical Fasteners
at 12" o.c. (6" from ends)
(By Installer)

- D. Sealant
Continuous Bead of Sealant, 3/8" Wide
(By Installer)
- E. Roofing or Single-Ply Membrane
(By Installer)

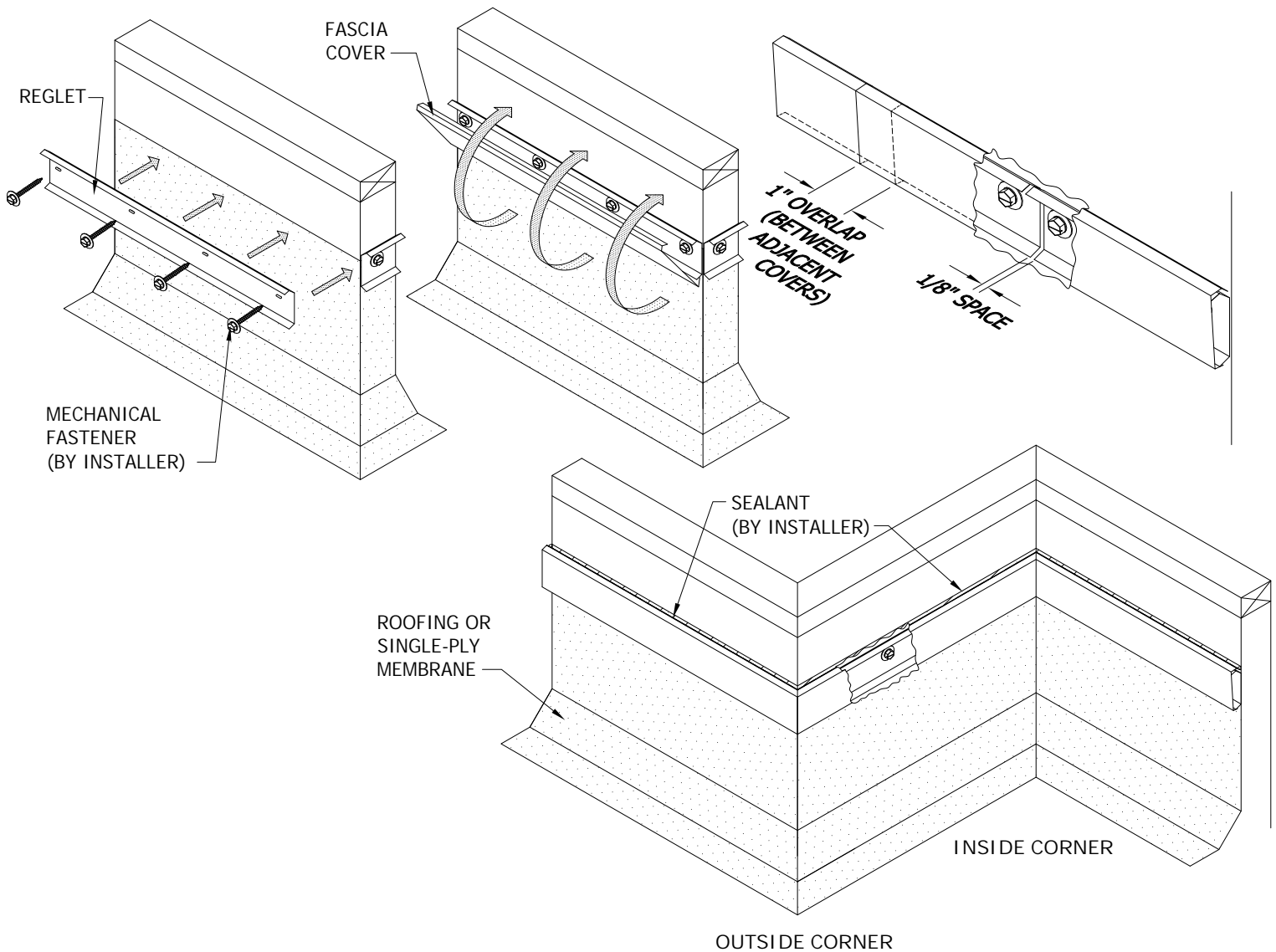

STEP 1: Installation of Reglet

Ensure that roofing membrane is continued up the side wall far enough to be covered by the reglet. Position the reglet as shown in the diagram above. Attach using the mechanical fasteners (by installer). Locate fasteners in each pre-punched holes. Space each 10'-0" section by 1/8" (or 1/4" in cold weather) to allow for thermal expansion.

STEP 2: Installation of Fascia Cover

Position the fascia cover as shown in the diagram above (parallel to the reglet). Hook the bottom of the fascia cover on the bottom lip of the reglet and push the top of the fascia cover until it snaps it into position. Lap each adjoining piece of counter flashing a min. of 1" to allow for thermal expansion. Stagger all fascia cover seams so that they do not align with reglet seams.

STEP 3: Installation of Sealant

Apply a continuous (3/8") wide bead of sealant to the top side of the counter flashing (see diagram above).

CORNER APPLICATION

Field bevel cut reglet and counter flashing for appropriate corner.