

**Issue Date: 10-01-2007**  
**Revision Date: 01-30-2019**  
**Renewal Date: 02-01-2020**

**DIVISION: 06 00 00 – WOOD, PLASTICS AND COMPOSITES**  
**Section: 06 63 00 – Plastic Railings**

**REPORT HOLDER:**

CertainTeed Corporation  
20 Moores Road  
Malvern, Pennsylvania 19355  
800-233-8990  
[www.certainteed.com](http://www.certainteed.com)

**REPORT SUBJECT:**

*Panorama™* Composite Guardrail System

### 1.0 SCOPE OF EVALUATION

**1.1** This Research Report addresses compliance with the following Codes:

- 2018, 2015 and 2012 *International Building Code®* (IBC)
- 2018, 2015 and 2012 *International Residential Code®* (IRC)

NOTE: This report references 2018 Code sections with [2015] Code sections shown in brackets where they differ.

**1.2** The *Panorama™* Composite Guardrail System has been evaluated for the following properties (see Table 1):

- Structural Performance
- Durability
- Surface Burning
- Decay Resistance
- Termite Resistance

**1.3** The *Panorama™* Composite Guardrail System has been evaluated for the following uses (see Table 1):

- The CertainTeed *Panorama™* system is a guard and guardrail system under the definitions of the referenced codes. They are intended for use at or near the open sides of elevated walking areas of buildings and walkways as required by the referenced codes.

- Guardrail systems recognized in this report may be used in One- and Two-Family Dwellings regulated by the IRC and all construction types regulated by the IBC in accordance with IBC Section 705.2.3.1 [1406.3], Exception 2. Guardrails less than 42 inches high are limited to use in One- and Two-Family Dwellings (IRC). See Table 1 for additional restrictions based upon Use and Occupancy Classification.

### 2.0 STATEMENT OF COMPLIANCE

The *Panorama™* Composite Guardrail System complies with the Codes listed in Section 1.1, for the properties stated in Section 1.2 and uses stated in Section 1.3, when installed as described in this report, including the Conditions of Use stated in Section 6.0.

### 3.0 DESCRIPTION

**3.1** Guard system includes universal rails used as both upper and lower rails, a top rail, vertical balusters, post sleeves, rail-to-post brackets, crush block, post trim ring and post cap.

**3.2** All rails (universal and top), composite balusters and post sleeves are manufactured from extruded shapes consisting of a PVC capped layer with a composite core. The composite core consists of wood fiber and polyvinyl chloride (PVC). The components are produced in three product colors: White, Almond, and Black. See Figure 1 for sectional profiles.

**3.3** The top rail assembly consists of two rails: a top rail assembled over a universal rail. See Figure 1.

**3.4** Top and bottom brackets are 0.5 inch by 0.855 inch by 0.080 inch thick series 409 stainless steel. See Figure 2.

**3.5** Composite balusters are 1.25 inch square composite material with PVC capstock. The balusters have beveled corners and are solid except for 4 extruded thru-holes. A small 0.075 inch diameter extruded hole is in the center of



each end of the balusters to provide a means for fastening. See Figure 1 for sectional profile.

**3.6** Colonial vinyl spindles are 1.25 inch square mono-extruded polyvinyl chloride (PVC) balusters that are thermoformed into a turned spindle shape through the mid-section of their length. See Figure 8. Vinyl balusters are held in place using polyvinyl chloride (PVC) “shoes” attached to the rails. See Figure 9.

**3.7** Metal balusters are manufactured from G90 zinc coated and powder coat steel. The four styles of steel balusters are shown in figures 3 through 6. Metal balusters are held in place using nylon “shoes” attached to the rails. See Figure 7.

#### 4.0 PERFORMANCE CHARACTERISTICS

**4.1** The CertainTeed Panorama™ guard system described in this report has demonstrated the capacity to resist the design loadings specified in Chapter 16 of the IBC, Section R301 of IRC, when tested in accordance with ICC-ES AC174. See Table 1.

**4.2** Structural performance has been demonstrated for a temperature range from -20°F to 125°F.

**4.3** Materials used are deemed equivalent to preservative treated or naturally durable wood for resistance to weathering effects, decay, and attack from termites.

**4.4** The composite core material with PVC capstock and the mono-extruded polyvinyl chloride (PVC) have flame spread indices not exceeding 200 when tested in accordance with ASTM E 84.

#### 5.0 INSTALLATION

The *Panorama™* Composite Guardrail System must be installed in accordance with the manufacturer’s published installation instructions, the applicable Code, and this Research Report. A copy of the manufacturer’s instructions must be available on the jobsite during installation.

**5.1** Composite balusters are held-in-place with a #8 by 2.5 inches stainless steel (SST) flat-head, self-starting screw inserted through holes pre-drilled, on 4 7/8 inches centers,

in the Universal support and into a pilot hole in each end of the baluster.

**5.2** PVC balusters are held in place using PVC “shoes” (see Figure 9) secured to the rails using a single #9 by 3 inches long wood screw through each shoe and into the rail. The PVC balusters are inserted over the extended portion of each shoe.

**5.3** Steel balusters are held in place using nylon “shoes” inserted over the extended portion of each shoe.

**5.4** SST top and bottom mounting brackets attach to the bottom of the channel at each end of the universal rail. See Table 2 and Figure 2.

**5.5** The tapered end of the PVC crush block is installed into the channel of the lower universal rail. A single crush block shall be installed at mid-span of the bottom universal rail between the deck surface and the guard rail. See Table 2.

**5.6** The top and bottom universal rails are attached to conventional 4 by 4 wood posts sleeved with a 5 inches square composite post cover. A single 1/8 inch pilot hole is drilled through the sleeve and into the wood post followed by a 3/8 inch clearance hole drilled through the sleeve only at each bracket location. A 1/4 inch by 2 inches SST lag screw is passed through the metal mounting bracket, post sleeve and into the post to attach the rail. See Table 2.

**5.7** The top rail cap is secured to the upper universal rail with through the center holes in each of the two metal brackets and two additional screws evenly spaced along the top rail. There are a total of four screws attaching the top rail to the universal rail. See Table 2.

**5.8** Non-structural PVC post trim ring may be installed at the base of the Panorama™ 5 inches square post sleeve and a PVC post cap may be installed over the exposed end of the post sleeve after installing the sleeve over a 4 by 4 wood post.

**5.9** The wood in the supporting structure shall have a specific gravity of 0.50 or greater (Southern Yellow Pine or better) and a minimum thickness to allow full penetration of the bracket mounting screws.



**6.0 CONDITIONS OF USE**

**6.1** Installation must comply with this Research Report, the manufacturer’s published installation instructions, and the applicable Code. In the event of a conflict, this report governs.

**6.2** Installation must comply with this Research Report, the manufacturer’s published installation instructions and the applicable Code. In the event of a conflict, this report governs.

**6.3** See Section 1.3 for construction type(s) and use classification(s).

**6.4** Conventional wood supports for guards, including posts, are not within the scope of this report and are subject to evaluation and approval by the building official. Supports must satisfy the design load requirements specified in Chapter 16 of the IBC and must provide suitable material for anchorage of the rail brackets. Where required by the building official, engineering calculations and details shall be provided.

**6.5** Compatibility of fasteners and other metallic components with the supporting structure, including chemically treated wood, is not within the scope of this report.

**6.6** Only those types of fasteners and fastening methods described in this report have been evaluated for the installation of the CertainTeed *Panorama™* guard system; other methods of attachment are not within the scope of this report.

**6.7** Where required by the building official, engineering calculations and details shall be provided. The calculations shall verify that the anchorage complies with the building codes for the type and condition of the supporting construction.

**6.8** The *Panorama™* Composite Guardrail System is manufactured under a quality program with inspections by Intertek Testing Services NA, Inc.

**7.0 SUPPORTING EVIDENCE**

**7.1** Drawings and installation instructions submitted by the manufacturer.

**7.2** The reports of testing and engineering analysis demonstrating compliance with the performance requirements of ICC-ES AC174, *Acceptance Criteria for Deck Board Span ratings and Guardrail Systems (Guards and Handrails)*, revised December 2014.

**7.3** The reports of testing demonstrating compliance with ASTM D 7032-14 [10a], *Standard Specification for Establishing Performance Ratings for Wood-Plastic Composite Deck Boards and Guardrail Systems (Guards or Handrails)*.

**7.4** Documentation of an Intertek approved quality control system for the manufacturing of products recognized in this report.

**8.0 IDENTIFICATION**

The *Panorama™* Composite Guardrail System is identified with the manufacturer’s name (CertainTeed Corporation), address and telephone number, the product name (*Panorama™* Composite Guardrail System), the statements “ASTM D7032 Compliant” and “For Use in One- and Two-Family Dwellings Only”, the Intertek Mark as shown below, and the Code Compliance Research Report number (CCRR-0115).



**9.0 OTHER CODES**

This section is not applicable.





10.0 CODE COMPLIANCE RESEARCH REPORT USE

10.1 Approval of building products and/or materials can only be granted by a building official having legal authority in the specific jurisdiction where approval is sought.

10.2 Code Compliance Research Reports shall not be used in any manner that implies an endorsement of the product by Intertek.

10.3 Reference to the <https://bpdirectory.intertek.com> is recommended to ascertain the current version and status of this report.

TABLE 1 - RAILING SYSTEM BUILDING CODE RECOGNITION

Type	Baluster	Maximum Rail Dimensions (Length x Height) <sup>(1)</sup>	
		IRC	IBC
Level	Composite and Vinyl	92.75" x 36", 92.75" x 42"	92.75" x 42"
Level	Metal Balusters	92.75" x 36"	N/A

<sup>1</sup> Level railing lengths are maximum clear length between supports. Railing height is the minimum installed height from walking surface to top of top rail.

This Code Compliance Research Report ("Report") is for the exclusive use of Intertek's Client and is provided pursuant to the agreement between Intertek and its Client. Intertek's responsibility and liability are limited to the terms and conditions of the agreement. Intertek assumes no liability to any party, other than to the Client in accordance with the agreement, for any loss, expense or damage occasioned by the use of this Report. Only the Client is authorized to permit copying or distribution of this Report and then only in its entirety, and the Client shall not use the Report in a misleading manner. Client further agrees and understands that reliance upon the Report is limited to the representations made therein. The Report is not an endorsement or recommendation for use of the subject and/or product described herein. This Report is not the Intertek Listing Report covering the subject product and utilized for Intertek Certification and this Report does not represent authorization for the use of any Intertek certification marks. Any use of the Intertek name or one of its marks for the sale or advertisement of the tested material, product or service must first be approved in writing by Intertek.





TABLE 2 - PANORAMA™ COMPOSITE GUARDRAIL SYSTEM FASTENING SCHEDULE

Connection		Fastener
Top and Bottom Brackets to Universal Rails		Two #10-12 by 3/4" stainless steel screws installed in first and third holes in connection bracket
Crush Blocks to Lower Universal Rail		Two #10 x 3/4" SST pan-head screws
Top and Bottom Brackets to Post		One 1/4-10 x 2" stainless steel lag screw
Top Rail Cap to Upper Universal Rail		Four #8-8 x 2-1/2" flat-head, self-starting, stainless steel screws
Composite Baluster to Universal Rail		One #8 x 2-1/2" flat-head, self-starting stainless steel wood screw at each end of the baluster
Colonial Vinyl Balusters	PVC "Shoe" to Universal Rail	One #9 x 3" flat-head, self-starting, stainless steel wood screw at each baluster "shoe"
	Vinyl Baluster to PVC "Shoe"	No mechanical connection - baluster is inserted over extended portion of "shoe"
Metal Balusters	Nylon "Shoe" to Universal Rail	One #9 x 3" flat-head, self-starting, stainless steel wood screw at each baluster "shoe"
	Metal Baluster to Nylon "Shoe"	No mechanical connection - baluster is inserted over extended portion of "shoe"

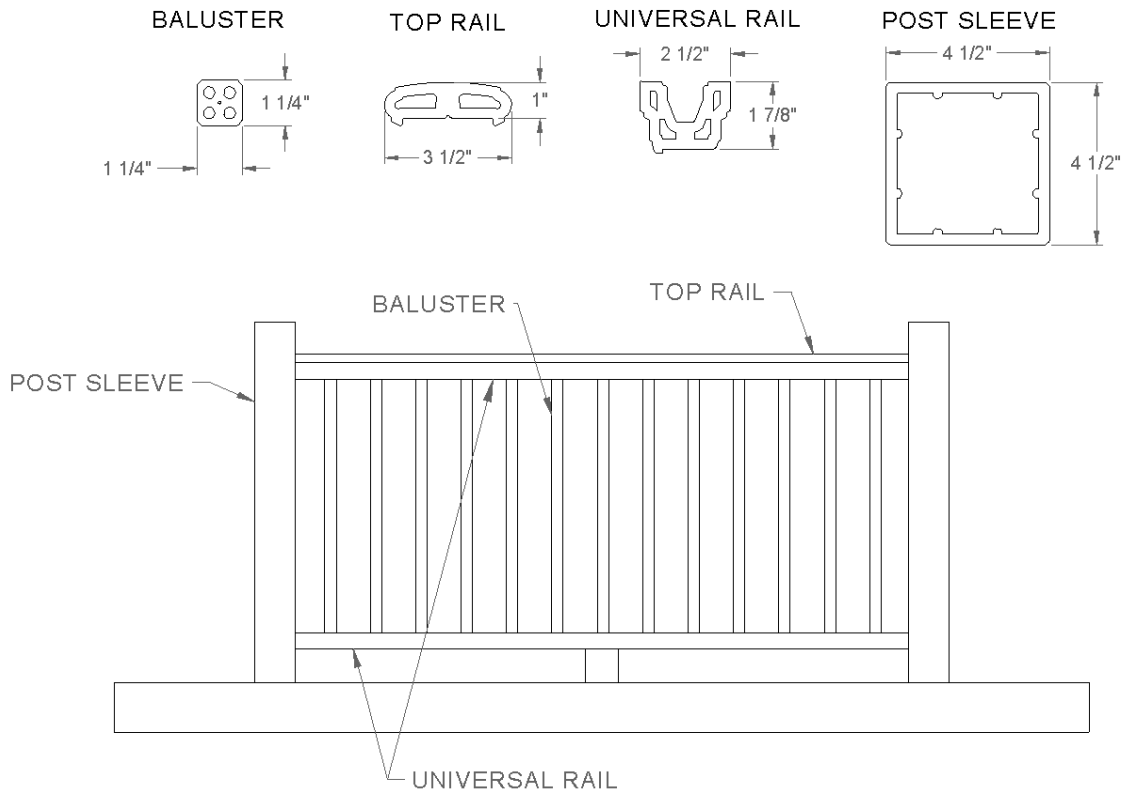

FIGURE 1 - PANORAMA™ COMPOSITE RAILING SYSTEM

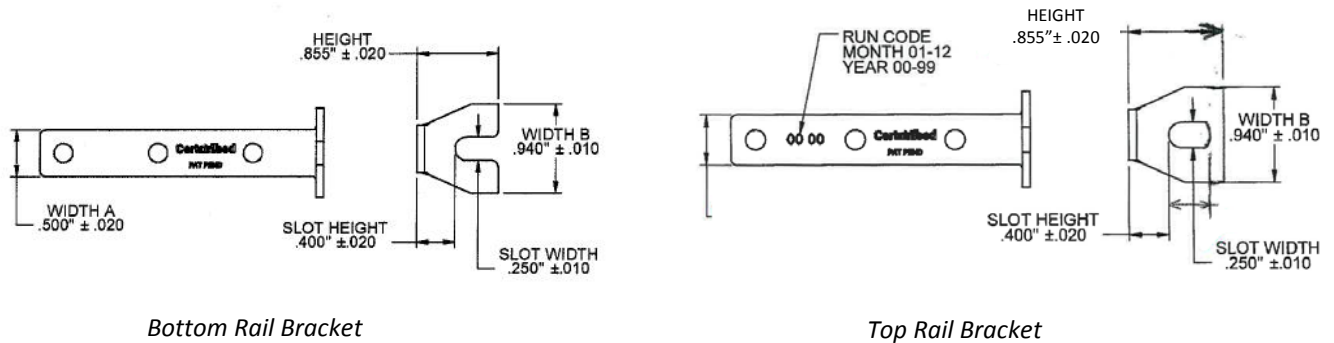

FIGURE 2 - PANORAMA™ ATTACHMENT BRACKETS

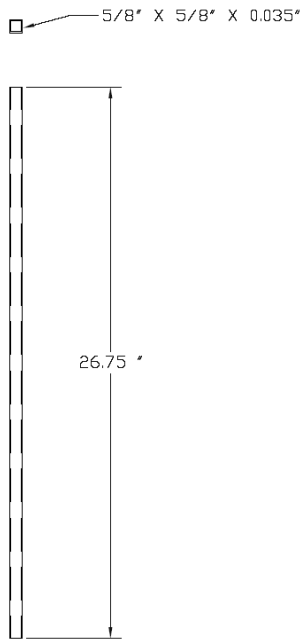

FIGURE 3 - STRAIGHT STEEL BALUSTER

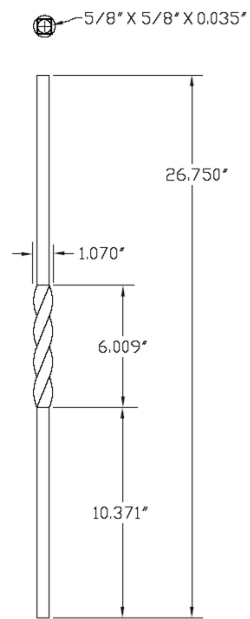

FIGURE 4 - TWISTED STEEL BALUSTER

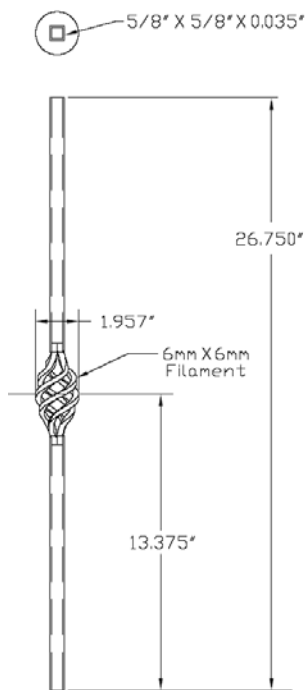

FIGURE 5 - ONE-BASKET STEEL BALUSTER

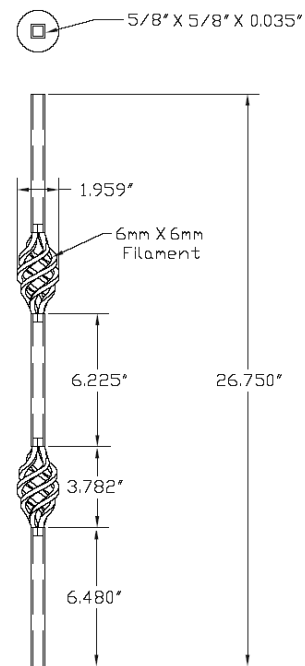

FIGURE 6 - TWO-BASKET STEEL BALUSTER

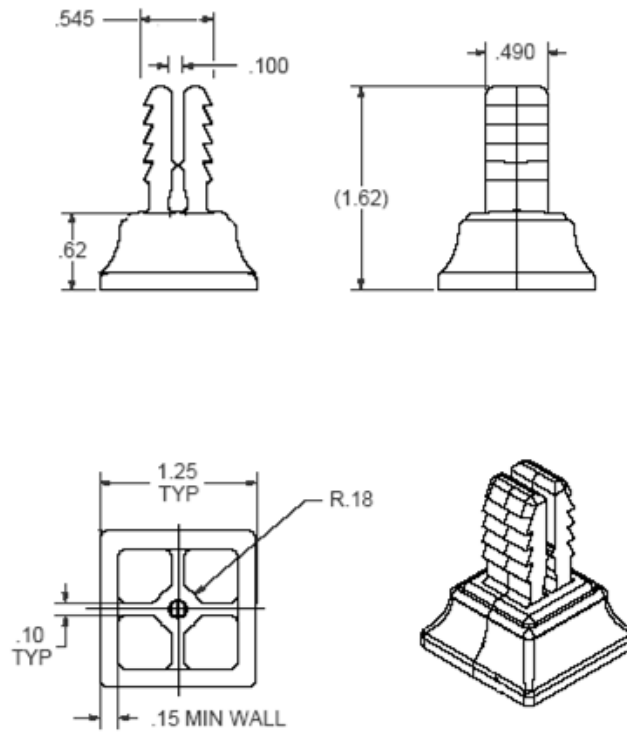

FIGURE 7 – NYLON BALUSTER "SHOE"

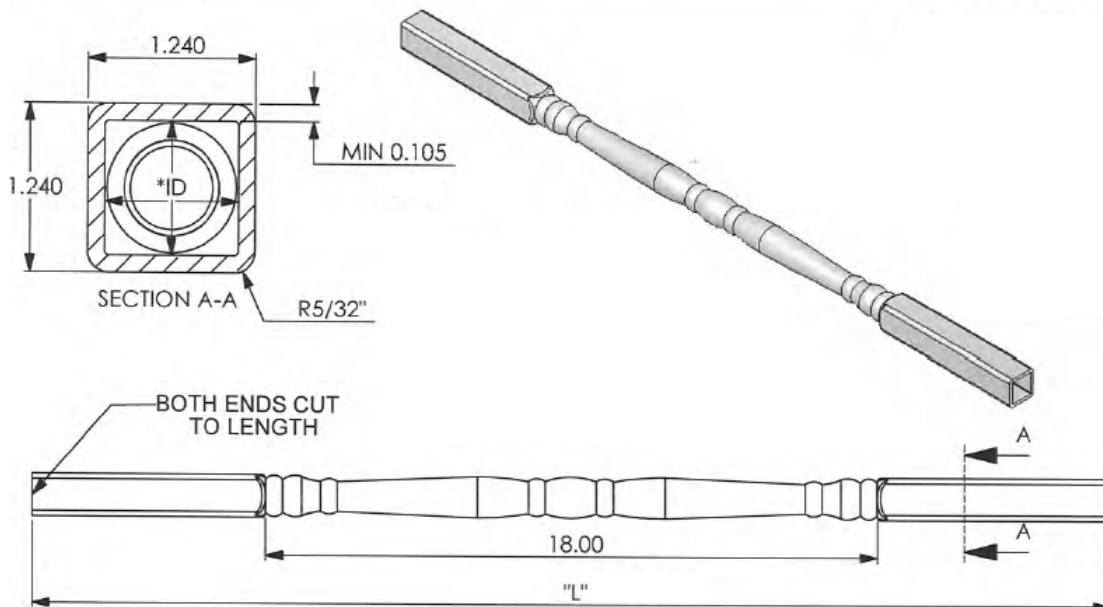

FIGURE 8 - COLONIAL VINYL BALUSTER



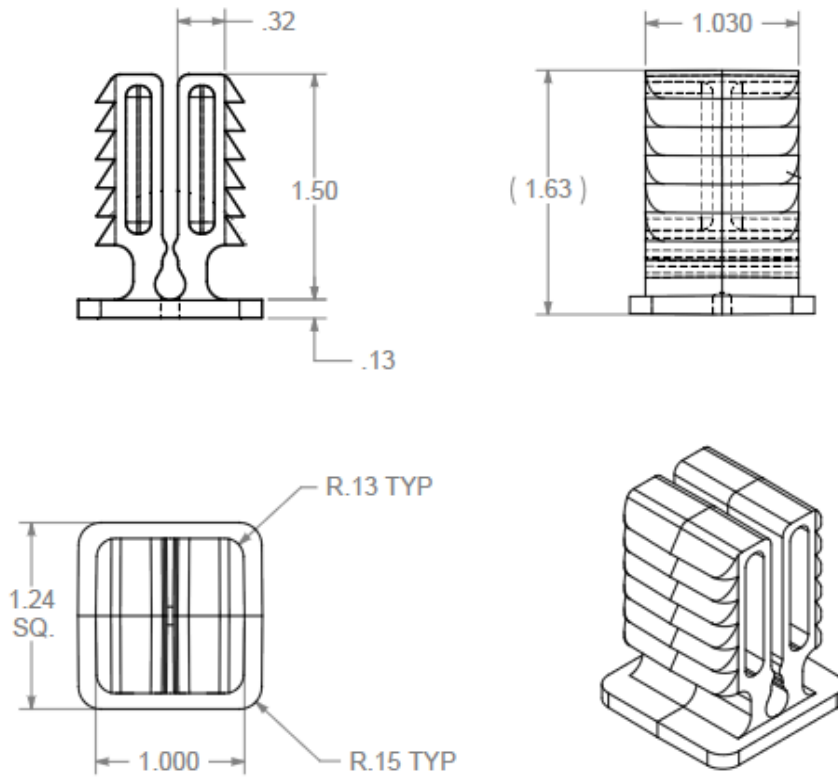

FIGURE 9 – PVC BALUSTER “SHOES”