

CertainTeed
SAINT-GOBAIN

GlasRoc[®] *SHAFTLINER*

For Area Separation Firewalls

GlasRoc® Shaftliner Type X for Area Separation Firewalls

GlasRoc®

GlasRoc® Shaftliner is a specially formulated product for applications where enhanced moisture and mold resistance is preferred. It can be used for firewalls in standard multi-family residential applications.

GlasRoc® Shaftliner Type X

GlasRoc® Shaftliner is a paperless mold and moisture resistant gypsum board combining reinforcing glass mats and a specially formulated fire and moisture resistive, non combustible core.

GlasRoc® Shaftliner offers:

- Long term protection (12 months) to weather exposure.
- A superior water resistant surface that does not inhibit water vapor permeance.
- Excellent fire resistance properties, and numerous fire rated designs.
- Resists mold growth per ASTM D3273.

The GlasRoc® Shaftliner Type X advantage...

GlasRoc® Shaftliner and M2Tech® Moisture and Mold Resistant gypsum boards can be combined to offer superior mold resistance performance for Area Separation Firewalls.

Gypsum Area Separation Firewall systems are ICC and NBCC Code Approved and replace traditional masonry for fire separation between multi-family units. Some inherent advantages of gypsum Area Separation Firewalls are: lighter weight, reduced thickness, ease and speed of installation, no requirement for scaffolding, and no

requirement for an additional trade on the job.

Area Separation Firewalls offer the advantages of fire resistance and noise attenuation between adjoining housing units. These walls offer a 2-hour fire resistance rating line of defense between units and provide sound ratings up to STC 61. For improved sound attenuation up to STC 65 substitute 1/2" (12.7 mm) SilentFX® QuickCut™ for 1/2" (12.7 mm) CertainTeed® Regular gypsum board in Area Separation Firewall systems.

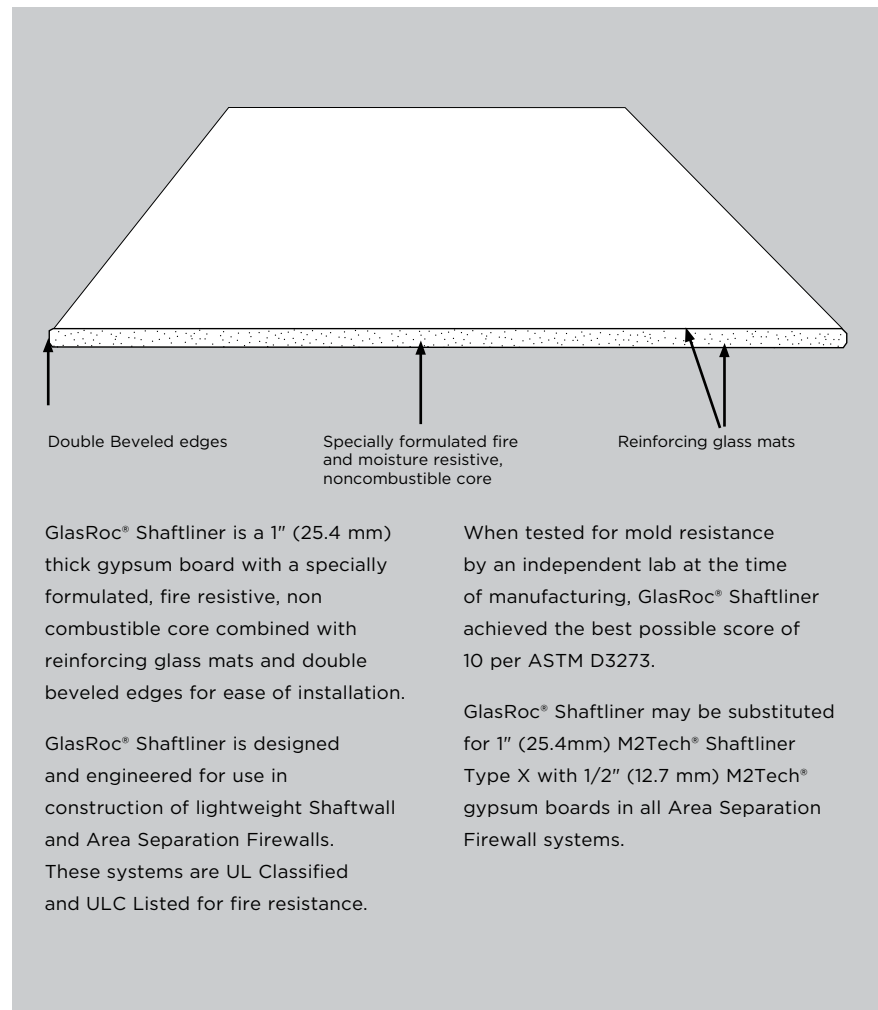

Area Separation Firewalls

GlasRoc® Shaftliner is used in conjunction with CertainTeed gypsum board products in Area Separation Firewalls.

Area Separation Firewalls are solid type separation walls assembled using 1" (25.4 mm) GlasRoc® Shaftliner gypsum board, metal framing and 1/2" (12.7 mm) CertainTeed® Regular, Easi-Lite®, M2Tech®, SilentFX® QuickCut™ or AirRenew® gypsum board for the interior finish. The firewall is easily stacked, floor to floor, allowing progressive construction.

Breakaway aluminum clips are used to attach the interior wall to adjacent structural metal framing and provide lateral support. When one side is exposed to fire, the clips yield from the heat and break away allowing the gypsum board interior wall on the fire side to collapse. Thus the Area Separation Firewall remains intact to protect neighboring spaces.

Area Separation Firewalls are easier and faster to construct, lighter weight, and take up less space than masonry wall systems.

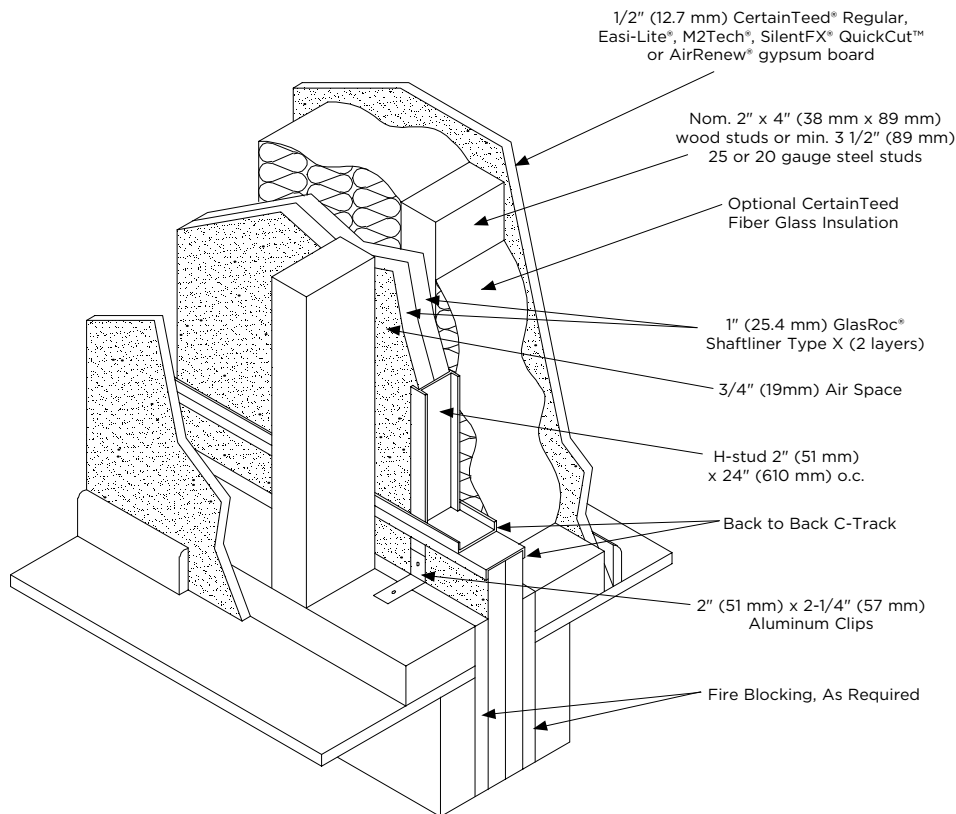

Thickness: 1" (25.4 mm)
Widths: 2' (610 mm) Standard
Lengths: 8' (2440 mm), 10' (3050 mm) and 12' (3660 mm) Standard
Edges: Double beveled



Working With the Product

Handling and Storage

GlasRoc® gypsum boards should be stacked flat on a smooth, level surface, not stored directly on the ground. When spacers are used, position them closely enough together to minimize warpage. Care should be taken to prevent damage to edges and corners. Always keep gypsum board dry prior to installation.

CertainTeed assumes no responsibility for consequential damages that may result from the presence of standing water or where moisture is in direct contact with Area Separation Firewall system components.

Cutting

The score and snap method is a fast and efficient way to cut gypsum board.

Steps:

1. On the logo side, position a straight edge along the line of the intended cut.
2. Score the glass mat sheet with a knife or other suitable tool.
3. With a quick, firm motion, snap back away from the face.
4. Score the back glass mat with a knife or other suitable tool and then snap the piece in the opposite direction.
5. Smooth all cut ends and edges to ensure tight joints.

To make cut outs, score around the

perimeter on the logo side and back side and tap out the waste piece from the logo side. Cut outs can also be made with a drywall saw. Gypsum boards can also be cut with a saw. Safety glasses should always be worn when using power tools. For information on avoiding dust inhalation, refer to the Safety Data Sheet available on our web site, www.certainteed.com.

Installation

Area Separation Firewall (Non-Loadbearing):

Steel framing and installation of 1" (25.4 mm) GlasRoc® Shaftliner gypsum board for solid type Area Separation Firewalls are used as the common wall of one unit. An Area Separation Firewall can be constructed by following these steps before continuing to frame the adjacent unit.

1. Attach 2" (51 mm) wide C-Track to slab at bottom of wall using suitable fasteners at a maximum of 24" (600 mm) o.c. Allow a 3/4" (19 mm) space from wood or steel stud framing on each side of the area separation firewall.
2. Install vertical C-Track at the beginning of the wall and support as needed.
3. Insert two sections of 1" (25.4 mm)

GlasRoc® Shaftliner, with the logo side facing weather exposure during construction, in the bottom channel and plumb to vertical C-Track.

4. Install 1" (25.4 mm) GlasRoc® Shaftliner gypsum boards vertically. Continue wall as needed by placing H-Studs between the proceeding panels every 24" (610 mm) for the length of the wall and enclose the end boards with vertical C-Track.
5. Cap the wall assembly before continuing higher using C-Track fastened to the H-Studs on alternate sides with 3/8" (10 mm) Type S screws. A second C-Track for the next row of shaftliner panels is then placed back to back with end joints staggered at least 12" (300 mm) o.c. and fastened with double 3/8" (10 mm) Type S screws at ends and 24" (600 mm) o.c.
6. Attachment Clips: Aluminum angle, 0.063" (1.6 mm) thick, min. 2" (51 mm) wide with min. 2" (51 mm) and 2-1/4" (57 mm) legs. Clips secured to each side of every H-Stud (two per stud) with 3/8" (10mm) Type S screws, and with Type W screws 1-1/4" (32 mm) long to wood framing or with Type S screws 3/8" (9.5 mm) long to steel studs through holes provided in the clip. Clips spaced a max

of 10' (3050 mm) o.c. vertically between wood or steel framing and H-Studs for separation firewalls up to 23' (7000 mm) high. For separation firewalls up to 44' (13400 mm) high, clips spaced as described above for the upper 24' (7300 mm) and the remaining wall area below requires clips spaced a max. 5' (1525 mm) o.c. vertically between wood framing and H-Studs.

- For separation firewalls greater than 44' (13400 mm) and up to 68' (20700 mm) high, clips are spaced a maximum 40" (1015 mm) o.c. for the lower 24' (7300 mm) section, a maximum 5' (1525 mm) o.c. for the 24' to 44' section and a maximum 10' (3050 mm) o.c. for the 44' to 68'.
- This assembly can be repeated, per plan, up to 68 feet (20700 mm) high. Cap the top of the assembly with 2" (51 mm) C-Track and protect the entire installation from moisture.
- Where required, use an approved acoustical sealant such as SilentFX® Noiseproofing Sealant to caulk around the perimeter of wall sections and between horizontal back-to-back C-Tracks.

Interior Finish Wall:

(Protected Wall - Loadbearing or Non-Loadbearing)

- Wood Studs - Nom 2" (38 mm) by 4" (89 mm) max. spaced 24" (610 mm) o.c. Steel Studs - Min. 3-1/2" (89 mm) 25 or 20 gauge steel studs max. spaced 24" (610 mm) o.c. Studs cross-braced at mid-height where necessary for clip attachment. Min. 3/4" (19 mm) separation between wood or steel framing and Area Separation Firewall.
- As an alternate to the 3/4" (19 mm) airspace the steel components are permitted to be covered with 6" (150 mm) wide batten strips of min. 1/2" (12.7 mm) CertainTeed® Type C gypsum board screwed to the C-Track and H-Studs with 1" (25.4 mm) Type S drywall screws spaced 12" (300 mm) o.c. Accessible attic areas typically use this alternate method to prevent homeowners from placing items in contact with or damaging the steel components. Non-accessible attic areas do not require the 6" (150 mm) wide gypsum board batten strips.
- Insulation (Optional) - CertainTeed CertaSound™ NoiseReducer™, Fiber Glass Building Insulation, or equivalent, installed between wood studs to meet listed STC performance.
- CertainTeed® Regular gypsum board or M2Tech® Moisture and Mold Resistant gypsum board, 1/2" (12.7 mm) thick, 4' (1220 mm) wide, applied either horizontally or vertically. Gypsum board attached to studs with 1-1/4" (32 mm) long drywall nails or 1-1/4" (32 mm) Type W drywall screws spaced 8" (200 mm) o.c. Gypsum board attached to steel studs with min. 1" (25.4 mm) Type S drywall screws spaced 12" o.c. (300 mm). Vertical joints located over studs. Joints and fasteners finished with CertainTeed Finishing system or equivalent.

Surface Preparation of Finished Sides

Joints, corners and fastener heads on the logo side shall be finished in accordance with ASTM C840, GA-214, GA-216, CAN/CSA-A82.31, GA Fire Resistance Design Manual GA-600 and joint compound manufacturer's instructions. Joint compound shall comply with ASTM C475.

- No surface treatment shall be done until the interior temperature has been maintained at a minimum of 50°F (10°C) for at least 48 hours prior to application of compounds and until all materials have completely dried. Adequate continuous ventilation must also be provided.
- Fill and level joints with CertainTeed® joint compound.
- Embed tape into the wet compound and allow to dry. For inside corners, crease the tape and work it into joint.
- Apply a second coat of compound across the joint and feather to approximately 4" (100 mm) on each side.
- Apply a third coat and feather to approximately 6" (150 mm) on each side.
- Allow each coat to dry before proceeding. Refer to GA-236 for the effects of environmental conditions on drying times.
- Attach corner bead to outside corners and apply three coats of joint compound. Feather out each coat as described in steps 4-6.
- Spot cover all fastener heads with three coats of joint compound applied in different directions.
- Lightly sand the last coat of all treated areas, taking care not to rough the surrounding gypsum board paper. Smoothing can also be accomplished with a damp sponge.

Finishing Interior Walls

CertainTeed gypsum board can be finished with paint, texture or wallpaper. High quality primer/sealer must be used prior to

any type of final decoration. For high gloss paint and severe lighting conditions, a thin skim coat of joint compound or CertainTeed® Level V Wall/Ceiling Primer Surfacer should be applied across the entire surface (Level 5 Finish). This will help minimize the irregularities and porosity differences between the materials. Refer to GA-214, GA-216, CAN/CSA-A82.31 and ASTM C840 for additional finishing instructions. Finishing is not required on the Area Separation Firewall.

Limitations

- Area Separation Firewalls are for non-loadbearing partitions only.
- CertainTeed gypsum board must not be used in areas that are continuously or repeatedly exposed to excessive moisture or dampness.
- Systems shall not be exposed to sustained temperatures exceeding 125°F (52°C).
- Do not use shaftliner boards in unlined air-supply ducts.
- GlasRoc® and CertainTeed gypsum boards should not come in direct contact with concrete, masonry or other surfaces that have a high moisture content.
- Unsupported wall height between floors should not exceed 12'0 (3660 mm). The assembly may be used in buildings up to 4 stories with a total height not to exceed 68' (20700 mm).
- Penetrations through the solid 2" (51 mm) Area Separation Firewall should be protected by a Firestop System in accordance with IBC, Chapter 7 and NBCC Part 3.1.9.
- Penetrations in the solid 2" (51 mm) Area Separation Firewalls designed as a Party Wall (a wall located on a property line between adjacent buildings which is used or adapted for joint service between the two buildings), i.e. town-homes, are usually not permitted by code authorities. Consult your local building code authority.

**Non-loadbearing
Fire Rating - 2 Hour**

EXPOSED TO FIRE FROM AREA SEPARATION FIREWALL SIDE ONLY

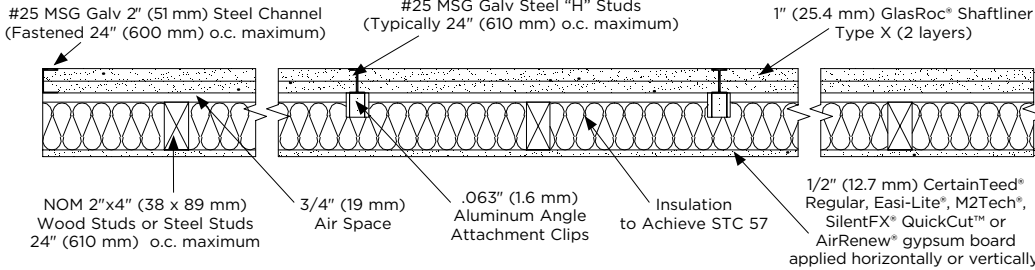

FIRE TEST
UL U366, ULC W311

SOUND TEST
RAL-TL00-177
STC 57

THICKNESS
6-3/4" (172 mm)

APPROX. WT.
10 psf (49 kg/m²)

EXPOSED TO FIRE FROM EITHER SIDE

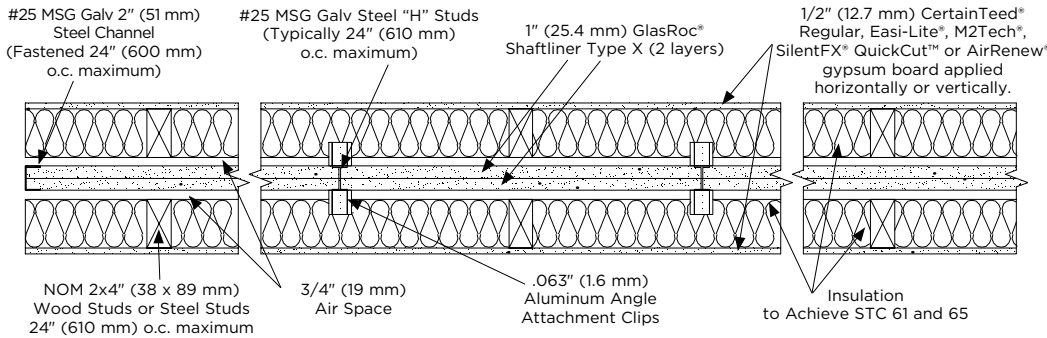

FIRE TEST
UL U366, ULC W311

SOUND TESTS
RAL-TL00-176
STC 61
with SilentFX®
QuickCut™ both sides
NGC 2017128
STC 65

THICKNESS
11 1/2" (292 mm)

APPROX. WT.
13 psf (63kg/m²)

TYPICAL INSTALLATION DETAILS

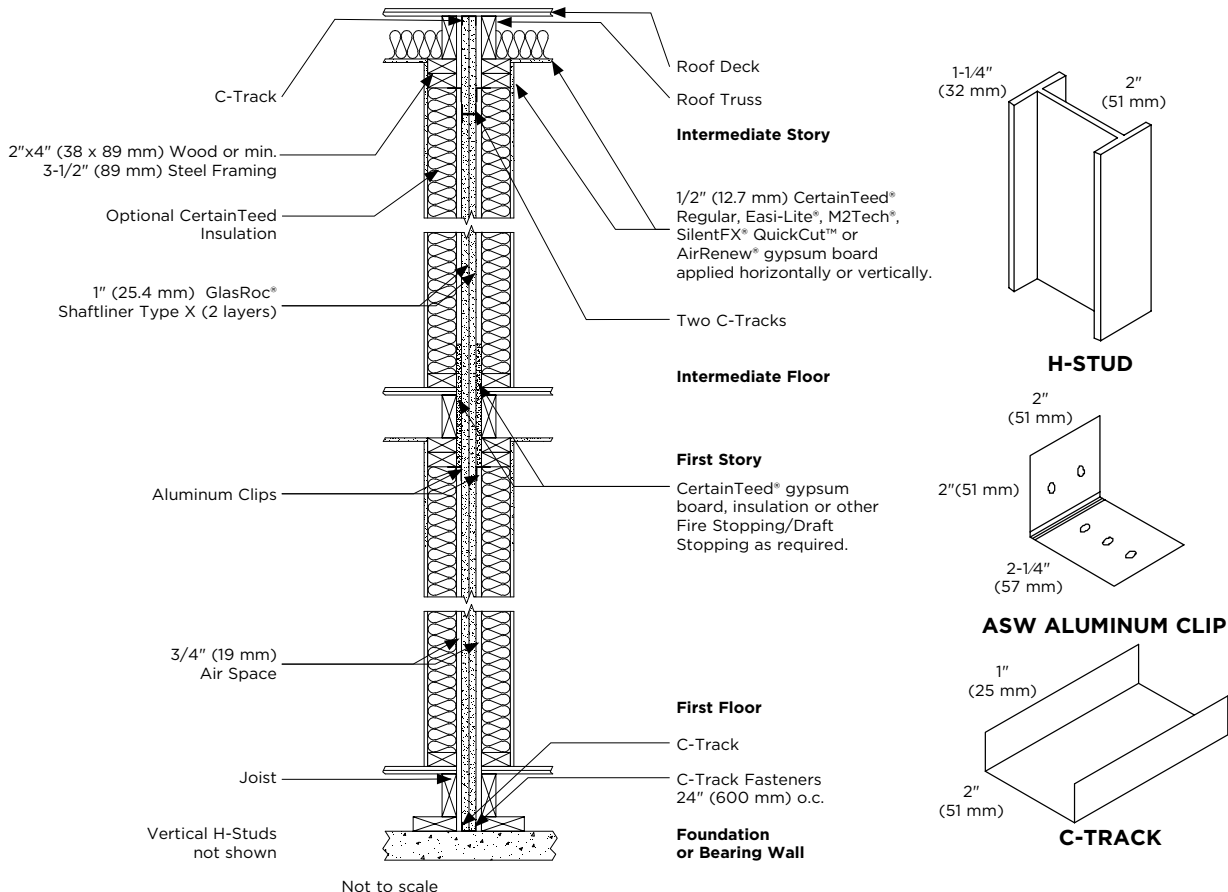

Not to scale

INTERMEDIATE FLOOR INTERSECTION LOCATION OF ASW CLIPS

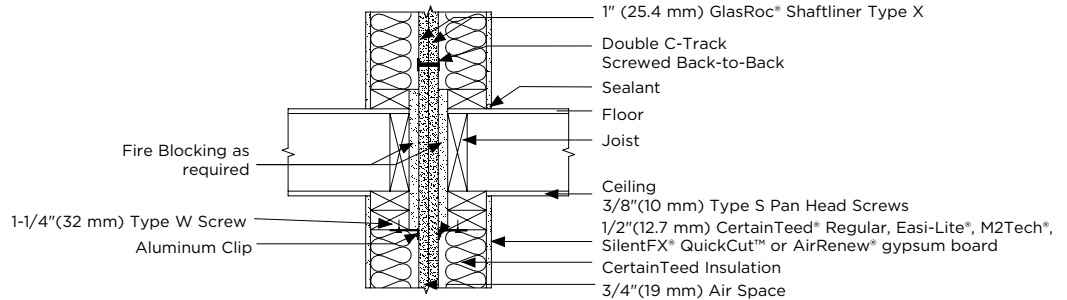

EXTERIOR WALL INTERSECTION

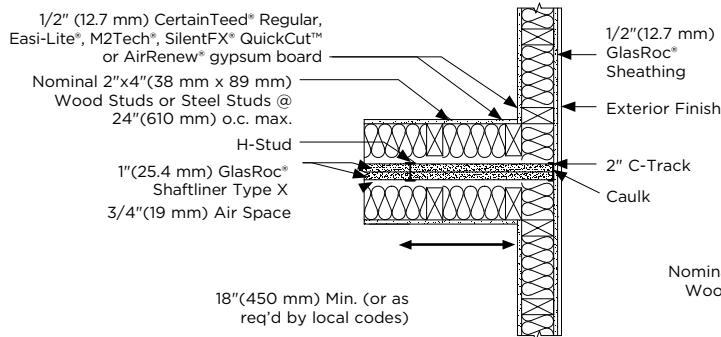

PROTRUDING EXTERIOR WALL

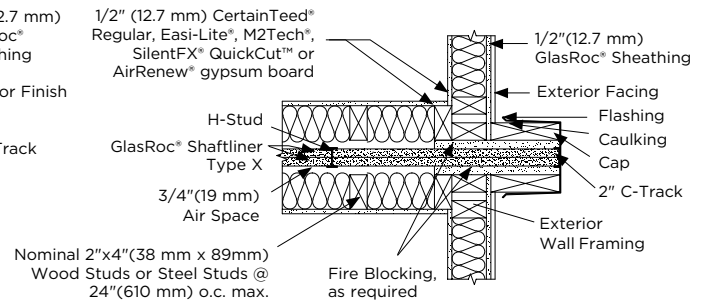

TYPICAL ROOF JUNCTION DETAIL

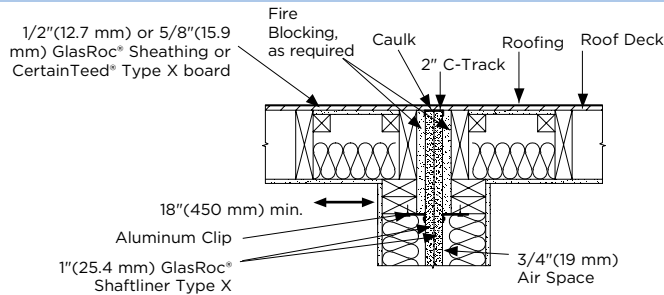

TYPICAL ROOF PARAPET DETAIL

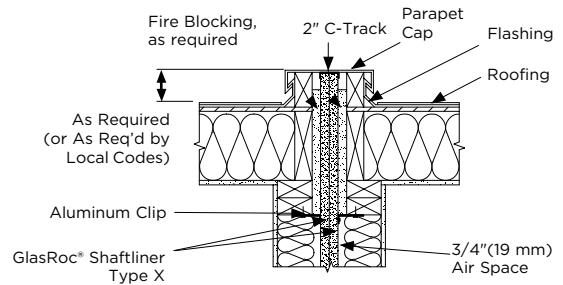

Component Specifications

GlasRoc® Shaftliner Type X		Steel
Standard	ASTM C1396; C1658; CAN/CSA A82.27	C-Track 25 ga, 2" (51 mm)
Thickness	1" (25.4 mm)	H-Stud 25 ga, 2" (51 mm)
Width	2' (610 mm)	Aluminum Clip .063" (1.6 mm), 2" (51 mm)
Lengths	8' (2440 mm), 10' (3050 mm), 12' (3660 mm)	
Approx. Weight	4.0 psf (19.5 kg/m ²)	
Edges	Double Beveled	

Consult local building codes for regulations in your area.

Surface Burning Characteristics

GlasRoc® Shaftliner Type X		
Standard	Flame Spread	Smoke Developed
ASTM E84	0	10 Class A
CAN/ULC-S102	0	20

Technical References

- ICC International Codes
- UL U366, ULC W311
- UL/ULC Type Designation: EGRG Shaftliner or GlasRoc Shaftliner
- Gypsum Association Publications GA-620, GA-214, GA-216, and GA-600
- ASTM E84 (CAN/ULC-S102), E119 (CAN/ULC-S101), E90
- ICC ESR-1338
- Riverbank Acoustical Laboratories TL00-176 and TL00-177
- National Building Code of Canada

GlasRoc[®] SHAFTLINER

CertainTeed
SAINT-GOBAIN

Gypsum



- 12 month limited warranty against weather exposure
- Resists mold growth per ASTM D3273
- UL Classified and ULC Listed for Fire Resistance
- Rapid ease of installation reduces overall construction time and provides a cost effective system
- Area Separation Firewall ratings up to two hours with high STC Ratings.

learn more at:
CertainTeed.com/drywall

Characteristics, properties or performance of materials or systems manufactured by CertainTeed herein described are derived from data obtained under controlled test conditions. CertainTeed makes no warranties, express or implied, as to their characteristics, properties or performance under any variations from such conditions in actual construction. CertainTeed assumes no responsibility for the effects of structural movement.

CertainTeed and the tag line "Quality made certain. Satisfaction guaranteed." are trademarks of CertainTeed Corporation. All other trademarks are the property of its affiliates and related companies.

NOTICE: The information in this document is subject to change without notice. CertainTeed assumes no responsibility for any errors that may inadvertently appear in this document.



CertainTeed Corporation

ROOFING • SIDING • TRIM • DECKING • RAILING • FENCE • GYPSUM • CEILINGS • INSULATION

20 Moores Road Malvern, Pa 19355 Professional: 800-233-8990 Consumer: 800-782-8777 certainteed.com