

Post Routing Template Kit

Routing template kit can be used to enlarge holes for racking as well as to create transitions for stepping, changing heights or styles.

Install 3/8" router blade and 5/8" bearing or router guide. Any substitutions may result in improper hole size or damage to the template kit.

NOTE: Template cutout size is designed to be 1/8" larger than the finished cut to allow bearing to follow the shape.

Select the appropriate template for the application.

Assemble the template as shown, configured for the desired post size (4" or 5").

NOTE: It is advisable to practice routing on a scrap piece before attempting actual cut.

Mark location of hole to be routed. Offset template cut by 1/8" to allow for bearing (i.e., if hole is to be located 3" from top of post, position edge of template 2-7/8" from top).

Tighten wing nuts. Place on a flat, firm surface to prevent tipping.

Route hole per manufacturer's recommendations.

ALWAYS WEAR SAFETY GLASSES.

Loosen wing nut and remove template.

For situations that require a larger hole to accommodate racking, route a standard hole, loosen wing nuts and slide template to new position to route excess material.

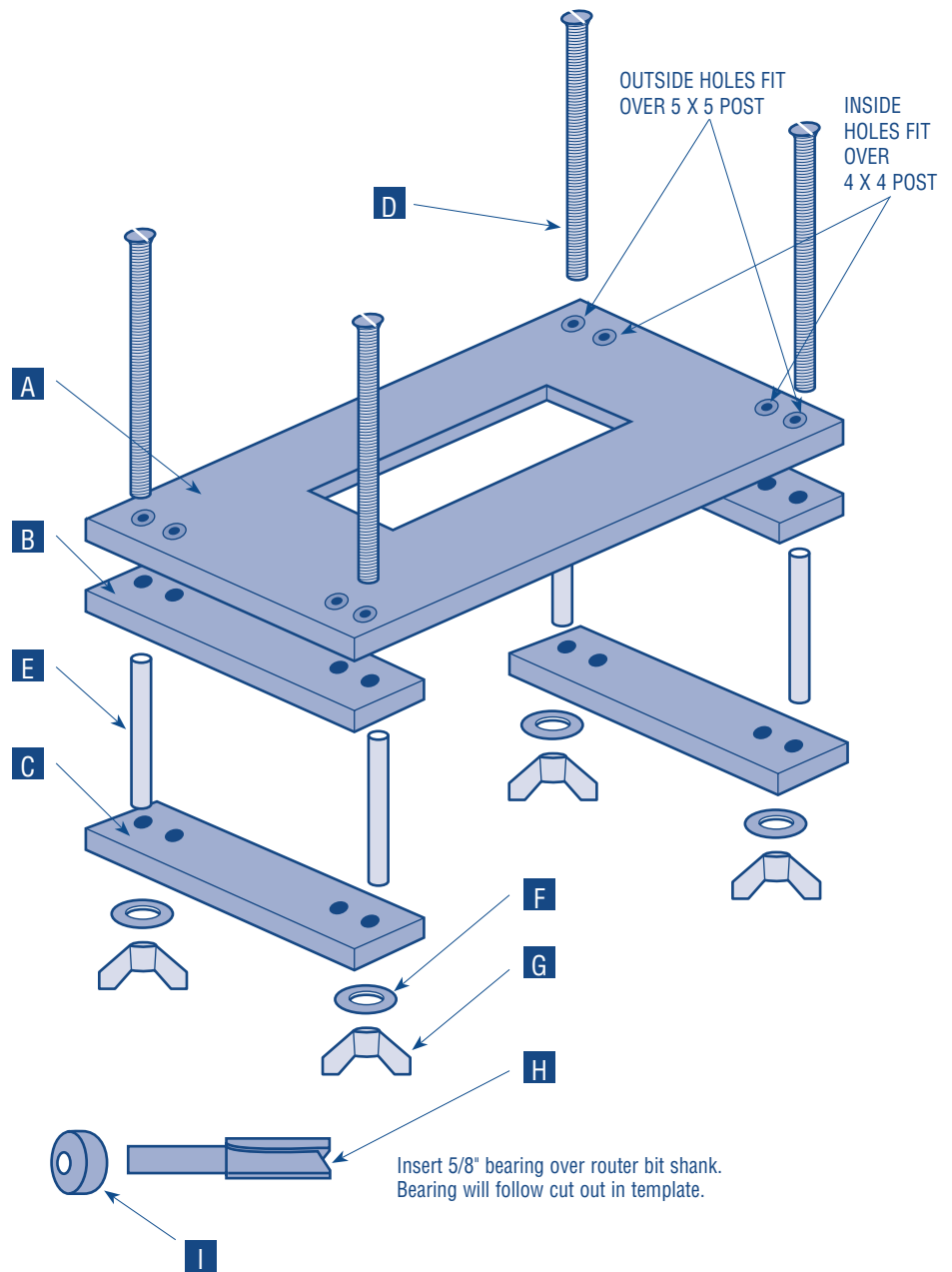

- A** ROUTING TEMPLATE
- B** 1-1/8" TEMPLATE SPACER PLATE
- C** 1-1/2" TEMPLATE SPACER PLATE
- D** 1/4" -20 X 6" BOLTS
- E** 3/8" OD PLEXI TUBE
- F** 1/4" FLAT WASHER
- G** 1/4" -20 WING NUT
- H** 3/8" ROUTER BIT W/ 1/4" SHANK
- I** 5/8" BEARING W/ 1/4" ID OPENING