

ICC-ES Evaluation Report

ESR-1668

Reissued March 1, 2009

This report is subject to re-examination in two years.

www.icc-es.org | (800) 423-6587 | (562) 699-0543

A Subsidiary of the International Code Council®

DIVISION: 07—THERMAL AND MOISTURE PROTECTION
Section: 07450—Fiber-reinforced Cementitious Panels
REPORT HOLDER:
**CERTAINTEED CORPORATION—FIBERCEMENT
PRODUCTS DIVISION**
 750 EAST SWEDES FORD ROAD
 VALLEY FORGE, PENNSYLVANIA 19482
 (517) 787-1737
www.certainteed.com
EVALUATION SUBJECT:
**WEATHERBOARDS™ FIBERCEMENT LAP SIDING,
VERTICAL PANEL SIDING, SOFFIT PANELS AND
SHAPES SIDING**
1.0 EVALUATION SCOPE
Compliance with the following codes:

- 2006 *International Building Code*® (IBC)
- 2006 *International Residential Code*® (IRC)
- BOCA® *National Building Code/1999* (BNBC)
- 1999 *Standard Building Code*® (SBC)
- 1997 *Uniform Building Code*™ (UBC)

Properties evaluated:

- Weather resistance
- Transverse loading
- Surface burning characteristics
- Fire-resistive-rated construction

2.0 USES

Certainteed's WeatherBoards™ fibercement lap and panel products are intended for use as exterior wall coverings and soffits.

3.0 DESCRIPTION

Weatherboards™ products are autoclaved, single-faced wall coverings manufactured from a proprietary mixture of cellulose fiber, portland cement, silica, clay or fly ash and limestone. See Table 1 for dimensions and surface texture. See Table 2 for wind pressures according to the wind speed from the applicable code and the mean roof height. See Table 3 for allowable wind pressures, fastener schedules, and installation requirements. Wind pressures noted in Table 3 are allowable values for positive and negative directions. See Table 4 for allowable fastener withdrawal capacities.

WeatherBoards™ exhibit a flame-spread index of 25 or less and smoke-developed index of 450 or less when tested in accordance with ASTM E 84.

WeatherBoards™ lap and vertical panel siding products are recognized in this report as a component of a one-hour, fire-resistance-rated, limited-load-bearing, wood-stud wall assembly, where installed in accordance with Section 4.6 of this report.

Lap siding, vertical panel siding, soffit panels and shapes siding come in lengths and widths as described in Table 1. All edges are square. Shapes siding is a panel-type product available with various designs.

4.0 INSTALLATION
4.1 General:

The lap, vertical panel and shapes sidings shall be installed over nominally 2-inch-thick (51 mm) wood or minimum No. 20 gage [0.036 inch (0.91 mm)], 3.625-inch-by-1.375-inch (92 by 34.9 mm), 33 ksi steel, C-stud framing members. A water-resistive barrier complying with the applicable code shall be installed under the siding. A water-resistive barrier and sheathing shall be installed in accordance with the applicable code. Fasteners shall be spaced no closer than 3/4 inch (19.1 mm) from the panels' horizontal edges, and shall be no closer than 3/8 inch (9.5 mm) to the panel vertical edges. Fasteners shall be corrosion-resistant and sized as specified in Tables 3 and 4 of this report. Installation shall comply with this report and the manufacturer's application instructions.

Where nonstructural or nonfastener base structural sheathing is used under the siding, fastener length shall be increased to provide a minimum 1 1/4-inch (31.8 mm) penetration into the framing. Blind fastening is acceptable on lap siding installed according to the assemblies noted in Table 3 and Figure 2 of this report.

The installation of the WeatherBoards™ shall be limited to Type V for jurisdictions adopting the IBC, UBC or BNBC, and Type VI for jurisdictions adopting the SBC. Certain limited exceptions exist within each code as noted below:

- IBC: For Types I, II, III and IV construction, WeatherBoards™ shall be installed in accordance with Section 1405.15.
- BNBC: For Types 1, 2, 3 and 4 construction, WeatherBoards™ are permitted to be installed up to 40 feet (12192 mm) in height above the grade plane.
- SBC: For Types I, II, III, IV and V construction, WeatherBoards™ shall be installed in accordance with Section 1403.6.7.

- UBC: For Types I, II, III and IV construction, WeatherBoards™ shall be installed in accordance with Section 601.5.4(2).

4.2 Lap Siding:

Lap siding shall be applied horizontally, commencing from the bottom of a wall, and with a minimum 1¹/₄-inch-wide (31.8 mm) overlap at the top of each board. Vertical joints between planks shall be over studs and shall be staggered on subsequent courses. These vertical joints between planks shall be lightly butted or gapped 1¹/₈ inch (3.2 mm), and shall be protected by one of the following methods: (a) sealed with caulking; or (b) covered with an H-section joint cover; or (c) located over a strip of flashing. Horizontal joints shall be flashed with Z-flashing and blocked with solid wood framing. A 1¹/₈-inch (3.2 mm) gap shall be left at locations where the siding butts against door and window trim and at corners; such gaps shall be flashed in accordance with the applicable code, then caulked. Trim and corners shall be installed and the siding shall be finished in accordance with the manufacturer's application instructions. A clear distance of 6 inches (152 mm) shall be maintained between the siding and the ground.

4.3 Vertical Panel Siding:

The vertical panel siding shall be applied with the long dimension of the panel in the vertical direction parallel to the framing. All panel edges shall be backed by nominally 2-inch or thicker wood or minimum No. 20 gage [0.036 inch (0.91 mm)], 3.625-inch-by-1.375-inch (92 by 34.9 mm), steel C-stud framing members. Vertical joints shall be lightly butted, shall occur over framing members, and shall be sealed with caulking or covered with battens. Horizontal joints shall be weatherproofed by leaving a 3¹/₈-inch (9.5 mm) gap, which shall be flashed with corrosion-resistant metal "Z" flashing and caulked. Where siding butts against door and window trim, and at corners, a 1¹/₈-inch (3.2 mm) gap shall be left and flashed in accordance with the applicable code and caulked. Trim and corners shall be installed and the siding shall be finished in accordance with the manufacturer's published application instructions. A clear distance of 6 inches (152 mm) shall be maintained between the siding and the ground.

4.4 Soffit Panels:

The soffit panels shall be attached to framing spaced a maximum of 24 inches (610 mm) on center, with the long dimension of the panel perpendicular to framing. Fasteners and fastener spacing shall be as described for vertical siding in Section 4.3 and Tables 3 and 4. Fasteners shall be stainless steel or hot-dipped galvanized, and fastener spacing shall not exceed 6 inches (152 mm) on center.

4.5 Shapes Panels:

Shapes siding is installed as is the lap siding noted in Section 4.2.

4.6 Transverse Wind Pressures:

WeatherBoards™ shall be attached to wall framing so that the allowable transverse wind load pressure (based on the siding size, framing spacing, and fastening schedule) noted in Table 3 exceeds the design wind pressures of the applicable code or as noted in Table 2 of this report. Additionally, the allowable fastener withdrawal capacity for the fastener, noted in Table 4 (based on fastener type specified for the assembly in Table 3, penetration, and framing species) shall exceed the minimum fastener load in pounds per fastener specified in Table 3.

In jurisdictions adopting the SBC, where design wind speeds in accordance with Figure 1606 of the SBC do not exceed 80 mph (35.8 m/s), installation shall be as follows: Siding shall be fastened to the wall framing with one

fastener per board at each stud. Stud spacing shall not exceed 24 inches (610 mm) on center. Fasteners shall be as specified in Table 3 or 4.

4.7 One-hour Fire-resistance-rated Assembly:

The lap and vertical panel siding products noted in Table 1 are recognized as components of one-hour, fire-resistance-rated, limited-load-bearing, wood-stud wall assemblies when constructed in accordance with Figure 1 of this report. Wall design is limited to the allowable stress design approach, using the edition of the National Design Specification for Wood Construction (NDS) specified in the applicable code. The allowable axial load for a wall assembly constructed with lap siding shall be the lesser of the following: (a) 49 percent or less of the allowable axial design stress calculated in accordance with the NDS referenced in the applicable code; (b) from the 2005 NDS, 1,200 pounds (5335 N) per 2-by-4 stud or 228.5 psi (1.57 N/mm²) when No. 2 southern pine studs are used in the construction of a wall having an unbraced height of 9 feet (2743.2 mm); (c) 0.78 F'_c ; or (d) 0.78 of the stress calculated for studs with a slenderness ratio l_e/d of 33. Allowable axial load for a wall assembly constructed with vertical panel siding is the lesser of the following: (a) 73.4 percent of the allowable axial design stress calculated in accordance with the NDS referenced in the applicable code; (b) from the 2005 NDS, 1,800 pounds (8000 N) per 2-by-4 stud or 342.9 psi (2.37 N/mm²) when No. 2 southern pine studs are used in construction of a wall having an unbraced height of 9 feet (2743.2 mm); or (c) 0.78 F'_c ; or (d) 0.78 of the stress calculated for studs with a slenderness ratio l_e/d of 33.

5.0 CONDITIONS OF USE

The Certainteed Fibercement products described in this report comply with, or are suitable alternatives to what is specified in, those codes listed in Section 1.0 of this report, subject to the following conditions:

- 5.1 The products shall be installed in accordance with this report and the manufacturer's instructions. In the event of a conflict, the instructions in this report shall govern.
- 5.2 Except as noted in Section 4.1, the products shall be limited to Type V (combustible) construction.
- 5.3 The products have not been evaluated for racking resistance. Walls must be braced by other means as required by the applicable code.
- 5.4 The products are manufactured in Roaring River, North Carolina, and White City, Oregon, under a quality control program with inspections by SGS U.S. Testing Inc. (AA-692).

6.0 EVIDENCE SUBMITTED

- 6.1 Data in accordance with the ICC-ES Acceptance Criteria for Fiber Cement Panels Used as Exterior Wall Siding (AC90), dated October 2005 (editorially revised January 2008).
- 6.2 Report of testing in accordance with ASTM E 119 and ASTM E 84.

7.0 IDENTIFICATION

The lap siding, vertical panel siding, soffit panels, and shapes siding shall bear a label noting the product name; the manufacturer's name; the name of the inspection agency (SGS U.S. Testing Co. Inc.); the manufacturing plant location; and the evaluation report number (ESR-1668).

**TABLE 1—DESCRIPTION OF WEATHERBOARDS™
FIBERCEMENT LAP AND VERTICAL SIDING AND SOFFITS**

PRODUCT TYPE		WIDTH	LENGTH	THICKNESS
Lap siding	Smooth	5 ¹ / ₄ , 6 ¹ / ₄ , 7 ¹ / ₄ , 8 ¹ / ₄ , 9 ¹ / ₄ , 12 inches	12 feet	5 ⁵ / ₁₆ inch
	Cedar	5 ¹ / ₄ , 6 ¹ / ₄ , 7 ¹ / ₄ , 8 ¹ / ₄ , 9 ¹ / ₄ , 12 inches	12 feet	5 ⁵ / ₁₆ inch
	Smooth Bead	7 ¹ / ₂ inches	12 feet	5 ⁵ / ₁₆ inch
	Textured Bead	7 ¹ / ₂ inches	12 feet	5 ⁵ / ₁₆ inch
	Select Cedar	6 ¹ / ₂ , 7 ¹ / ₂ , 8 ¹ / ₄ & 9 ¹ / ₂ inches	12 feet	5 ⁵ / ₁₆ inch
	Dutch Lap	8 ¹ / ₄ inches	12 feet	5 ⁵ / ₁₆ inch
Shapes siding	Perfection Shingle	8 ¹ / ₄ inches	12 feet	5 ⁵ / ₁₆ inch
	Random Square Straight Edge	16 inches (7-inch exposure)	48 inches	5 ⁵ / ₁₆ inch
	Random Square Staggered Edge	16 inches (7-inch exposure)	48 inches	5 ⁵ / ₁₆ inch
	Half Rounds	16 inches (7-inch exposure)	48 inches	5 ⁵ / ₁₆ inch
	Octagons	16 inches (7-inch exposure)	48 inches	5 ⁵ / ₁₆ inch
Vertical siding	Stucco	4 feet	8, 9, 10 feet	5 ⁵ / ₁₆ inch
	Cedar 8" Groove	4 feet	8, 9, 10 feet	5 ⁵ / ₁₆ inch
	Cedar (no groove)	4 feet	8, 9, 10 feet	5 ⁵ / ₁₆ inch
	Smooth	4 feet	8, 9, 10 feet	5 ⁵ / ₁₆ inch
Soffit	Cedar	12, 16, 24 inches	6, 7, 8, 9, 10 feet	5 ⁵ / ₁₆ inch
	Cedar Ventilated	12, 16, 24 inches		1 ¹ / ₄ inch
	Smooth	12 inches	12 feet	5 ⁵ / ₁₆ inch
	Smooth Ventilated	12 inches	12 feet	1 ¹ / ₄ inch

INSTRUCTIONS FOR THE USE OF TABLES 2 and 3

- STEP 1.** Determine the applicable wind provisions as indicated in Table 2, the code-specified wind speed and the mean building roof height.
- STEP 2.** Utilizing the applicable wind provisions, wind speed and the mean roof height, determine the design wind pressure from Table 2.
- STEP 3.** Based on the CertainTeed WeatherBoards™ product, the stud spacing, and the specified fastening schedule from Table 3 for the applicable code, determine the allowable wind pressure and the nail load for the assembly.
- STEP 4.** Compare the allowable wind pressure (from Table 3) to the design wind pressure (from Table 2). If the design wind pressure (from Table 2) is larger than the allowable design wind pressure (from Table 3), choose another assembly from Table 3 such that allowable design pressure (from Table 3) is greater than or equal to the design wind pressure (from Table 2).

TABLE 2—DESIGN WIND PRESSURES, IBC¹ AND IRC

WIND VELOCITY (Fastest Mile), mph	85	90	100	110	120	130	140	150
Mean Roof Height	Wall Wind Pressures, lbf/ft² (negative)							
15 ft	21.1	23.6	29.2	35.2	42.0	49.2	57.1	65.6
20 ft	22.4	25.2	31.1	37.5	44.8	52.5	60.9	69.9
25 ft	23.5	26.3	32.5	39.3	46.8	54.9	63.7	73.2
30 ft	24.4	27.3	33.7	40.7	48.6	57.0	66.1	75.9
40 ft	25.9	29.1	35.9	43.4	51.7	60.6	70.3	80.8
50 ft	27.1	30.4	37.6	45.4	54.1	63.5	73.6	84.6
60 ft	28.2	31.6	39.0	47.1	56.2	65.9	76.5	87.8

¹Design pressures taken from Table 1609.6.2.1(2), Wall Zone 5, Effective Wind Area of 10, multiplied by the adjustment factor for building height and exposure from Table 1609.5.2.1(4). Based on Exposure C with an Importance Factor of 1.0.

SBC					
WIND VELOCITY (Fastest Mile), mph	70	80	90	100	110
Mean Roof Height	Wall Wind Pressures, lbf/ft² (negative)				
15 ft	15.0	19.6	24.8	30.7	37.1
20 ft	16.3	21.3	27.0	33.3	40.3
25 ft	17.4	22.7	28.7	35.5	42.9
30 ft	18.3	23.9	30.3	37.4	45.2
40 ft	19.9	26.0	32.9	40.6	49.1
50 ft	21.2	27.7	35.0	43.2	52.3
60 ft	22.3	29.2	36.9	45.6	55.1

Based on Pressure Coefficient of 1.5 and a Use Factor of 1.0.

TABLE 2—DESIGN WIND PRESSURES, IBC¹ AND IRC (Continued)

		UBC						
WIND VELOCITY (Fastest Mile), mph		70	80	90	100	110	120	130
Mean Roof Height	C _e	Wall Wind Pressure, lbf/ft ² (negative)						
15 ft	1.06	20.0	26.1	33.1	40.7	49.3	58.7	68.8
20 ft	1.13	21.4	27.8	35.3	43.4	52.2	62.5	73.4
25 ft	1.19	22.5	29.3	37.1	45.7	55.3	65.9	77.3
30 ft	1.23	23.2	30.3	38.4	47.2	57.2	68.1	79.9
40 ft	1.31	24.8	32.2	40.9	50.3	60.9	72.5	85.1
50 ft	1.37	25.9	33.7	42.7	52.6	63.7	75.8	89.0
60 ft	1.43	27.0	35.2	44.6	54.9	66.5	79.2	92.9

Based on Exposure C and Pressure Coefficient C_q = 1.5. For Exposure B, wall wind pressures shall be permitted to be multiplied by 0.66.

		ASCE 7-93				
WIND VELOCITY (Fastest Mile), mph		70	80	90	100	110
Mean Roof Height		Wall Wind Pressure, lbf/ft ² (negative)				
15 ft		22.60	29.52	37.37	46.13	55.82
20 ft		24.54	32.05	40.57	50.08	60.60
25 ft		26.16	34.16	43.24	53.38	64.59
30 ft		27.56	35.99	45.55	56.24	68.04
40 ft		29.92	39.07	49.45	61.05	73.87
50 ft		31.89	41.65	52.71	65.07	78.74
60 ft		33.59	43.87	55.53	68.55	82.95

Based on Pressure Coefficient of 2.25 and an Importance Factor of 1.00.

		ASCE 7-95, NBBC						
WIND VELOCITY (3-second gust), mph		85	90	100	110	120	130	140
Mean Roof Height		Wall Wind Pressure, lbf/ft ² (negative)						
15 ft		24.81	27.81	34.34	41.55	49.44	58.03	67.30
20 ft		26.36	29.55	36.48	44.14	52.53	61.65	71.50
25 ft		27.62	30.97	38.23	46.26	55.06	64.62	74.94
30 ft		28.71	32.18	39.73	48.07	57.21	67.14	77.87
40 ft		30.50	34.19	42.21	51.08	60.78	71.34	82.73
50 ft		31.96	35.84	44.24	53.53	63.71	74.77	86.71
60 ft		33.2	37.24	45.97	55.63	66.20	77.69	90.11

Based on a Pressure Coefficient of 1.58, an Importance Factor of 1.00, an Exposure C and K_{zt} = 1.0. With Exposure B on all four sides, design wind pressure shall be permitted to be multiplied by 0.85.

GENERAL NOTES:

¹Design wind pressures specified above shall be less than the applicable maximum allowable wind load pressure specified in Table 4 of this report.

²Internal pressure effects are based on an enclosed building.

³As an alternative to the design wall pressures above or where not applicable, structural calculations shall be provided in accordance with the applicable code.

⁴Design wind pressures are based on components and cladding corner edge zone.

⁵For SI: 1 mph = 1.61 km/h; 1 lbf/ft² = 47.8803 kPa; 1 ft = 304.8 mm.

TABLE 3 - ALLOWABLE WIND PRESSURES AND REQUIRED FASTENER SCHEDULE

PRODUCT	PRODUCT DIMS (in.)		FASTENER TYPE	FASTENING METHOD ¹	FRAMING TYPE	FRAMING SPACING (in)	ALLOWABLE WIND PRESSURES (lbf/ft ²) AND FASTENER LOAD ² (pounds)			
	Thick.	Width					Uniform Building Code	BOCA National Building Code	Standard Building Code	International Building Code
Vertical Siding	5/16	48	8d box nails	Face nailed 4" edge 8" field	2x4 #2 SPF	16	51 Fastener Load: 45	61 Fastener Load: 54	76 Fastener Load: 68	61 Fastener Load: 54
Vertical Siding	5/16	48	8d box nails	Face nailed 4" edge 8" field	2x4 #2 SPF	24	34 Fastener Load: 45	40 Fastener Load: 54	51 Fastener Load: 67	40 Fastener Load: 54
Vertical Siding	5/16	48	6d box nails	Face nailed 4" edge 8" field	2x4 #2 SPF	16	44 Fastener Load: 39	52 Fastener Load: 47	66 Fastener Load: 58	52 Fastener Load: 47
Vertical Siding	5/16	48	6d box nails	Face nailed 4" edge 8" field	2x4 #2 SPF	24	31 Fastener Load: 41	37 Fastener Load: 49	46 Fastener Load: 61	37 Fastener Load: 49
Vertical Siding	5/16	48	6d box nails	Face nailed 6" edge 12" field	2x4 #2 SPF	16	35 Fastener Load: 47	42 Fastener Load: 56	53 Fastener Load: 70	42 Fastener Load: 56
Vertical Siding	5/16	48	6d box nails	Face nailed 6" edge 12" field	2x4 #2 SPF	24	23 Fastener Load: 47	28 Fastener Load: 56	35 Fastener Load: 70	28 Fastener Load: 56
Vertical Siding	5/16	48	6d nails, HD Galv., Maze Nails #200HD-018	Face nailed 12" edge 12" field	2x4 #2 SPF	16	15 Fastener Load: 20	18 Fastener Load: 24	23 Fastener Load: 30	18 Fastener Load: 24
Vertical Siding	5/16	48	6d nails, HD Galv., Maze Nails #200HD-018	Face nailed 12" edge 12" field	2x4 #2 SPF	24	13 Fastener Load: 26	16 Fastener Load: 31	20 Fastener Load: 39	16 Fastener Load: 31
Vertical Siding	5/16	48	1 5/8", steel, self-tapping screw, 3/8" phillips head, ITW Buildex "Rock-On" S-12 #2159500	Face screwed 12" edge 12" field	Min. 20 ga., 3.625"x 1.375" Metal C-stud	24	18 Fastener Load: 37	22 Fastener Load: 44	27 Fastener Load: 56	22 Fastener Load: 44
Vertical Siding	5/16	48	1 5/8", steel, self-tapping screw, 3/8" phillips head, ITW Buildex "Rock-On" S-12 #2159500	Face screwed 12" edge 12" field	Min. 20 ga., 3.625"x 1.375" Metal C-stud	16	25 Fastener Load: 33	30 Fastener Load: 40	38 Fastener Load: 50	30 Fastener Load: 40
12" Lap Siding	5/16	12.00	1 5/8", steel, self-tapping screw, 3/8" phillips head, ITW Buildex "Rock-On" S-12 #2159500	Face screwed	Min. 20 ga., 3.625"x 1.375" Metal C-stud	16	27 Fastener Load: 32	32 Fastener Load: 38	41 Fastener Load: 48	32 Fastener Load: 38
12" Lap Siding	5/16	12.00	1 5/8", steel, self-tapping screw, 3/8" phillips head, ITW Buildex "Rock-On" S-12 #2159500	Blind screwed	Min. 20 ga., 3.625"x 1.375" Metal C-stud	16	25 Fastener Load: 30	30 Fastener Load: 36	38 Fastener Load: 45	30 Fastener Load: 36
12" Lap Siding	5/16	12.00	8d box nails	Face nailed	2x4 #2 SPF	16	55 Fastener Load: 66	66 Fastener Load: 79	83 Fastener Load: 99	66 Fastener Load: 79
12" Lap Siding	5/16	12.00	8d box nails	Face nailed	2x4 #2 SPF	24	49 Fastener Load: 88	59 Fastener Load: 106	74 Fastener Load: 133	59 Fastener Load: 106
9 1/4" Lap Siding	5/16	9.25	8d box nails	Face nailed	2x4 #2 SPF	16	76 Fastener Load: 70	91 Fastener Load: 84	114 Fastener Load: 105	91 Fastener Load: 84
9 1/4" Lap Siding	5/16	9.25	8d box nails	Face nailed	2x4 #2 SPF	24	64 Fastener Load: 88	76 Fastener Load: 106	96 Fastener Load: 133	77 Fastener Load: 106
9 1/4" Lap Siding	5/16	9.25	6d box nails	Face nailed	2x4 #2 SPF	16	50 Fastener Load: 46	60 Fastener Load: 55	75 Fastener Load: 68	60 Fastener Load: 55

TABLE 3 - ALLOWABLE WIND PRESSURES AND REQUIRED FASTENER SCHEDULE (Continued)

PRODUCT	PRODUCT DIMS (in.)		FASTENER TYPE	FASTENING METHOD ¹	FRAMING TYPE	FRAMING SPACING (in)	ALLOWABLE WIND PRESSURES (lb/ft ²) AND FASTENER LOAD ² (pounds)			
	Thick.	Width					Uniform Building Code	BOCA National Building Code	Standard Building Code	International Building Code
9 1/4" Lap Siding	5/16	9.25	6d box nails	Blind nailed	2x4 #2 SPF	24	25 Fastener Load: 34	30 Fastener Load: 41	37 Fastener Load: 51	30 Fastener Load: 41
9 1/4" Lap Siding	5/16	9.25	6d 2" Roofing nails, HD Galv., Maze Nails #HD-105	Blind nailed	2x4 #2 SPF	16	36 Fastener Load: 32	44 Fastener Load: 39	55 Fastener Load: 49	44 Fastener Load: 39
9 1/4" Lap Siding	5/16	9.25	6d 2" Roofing nails, HD Galv., Maze Nails #HD-105	Blind nailed	2x4 #2 SPF	24	28 Fastener Load: 37	34 Fastener Load: 45	42 Fastener Load: 56	34 Fastener Load: 45
9 1/4" Lap Siding	5/16	9.25	7d nails, HD Galv., Maze Nails #225HD-022	Face nailed	2x4 #2 SPF	16	68 Fastener Load: 61	82 Fastener Load: 73	103 Fastener Load: 91	82 Fastener Load: 73
9 1/4" Lap Siding	5/16	9.25	7d nails, HD Galv., Maze Nails #225HD-022	Face nailed	2x4 #2 SPF	24	45 Fastener Load: 60	54 Fastener Load: 72	68 Fastener Load: 91	54 Fastener Load: 72
9 1/4" Lap Siding	5/16	9.25	7d nails, HD Galv., Maze Nails #225HD-022 into OSB ³	Face nailed	2x4 #2 SPF w/ 7/16" OSB ³	16	91 Fastener Load: 81	109 Fastener Load: 97	136 Fastener Load: 121	109 Fastener Load: 97
9 1/4" Lap Siding	5/16	9.25	7d nails, HD Galv., Maze Nails #225HD-022 into OSB ³	Face nailed	2x4 #2 SPF w/ 7/16" OSB ³	24	70 Fastener Load: 93	84 Fastener Load: 111	104 Fastener Load: 139	84 Fastener Load: 111
9 1/4" Lap Siding	5/16	9.25	6d nails, HD Galv., Maze Nails #200HD-018 into OSB ³	Blind nailed	2x4 #2 SPF w/ 7/16" OSB ³	16	83 Fastener Load: 74	100 Fastener Load: 89	125 Fastener Load: 111	100 Fastener Load: 89
9 1/4" Lap Siding	5/16	9.25	6d nails, HD Galv., Maze Nails #200HD-018 into OSB ³	Blind nailed	2x4 #2 SPF w/ 7/16" OSB ³	24	67 Fastener Load: 90	81 Fastener Load: 108	101 Fastener Load: 134	81 Fastener Load: 108
9 1/4" Lap Siding	5/16	9.25	1 5/8", steel, self-tapping screw, 3/8" phillips head, ITW Buildex "Rock-On" S-12 #2159500	Face screwed	Min. 20 ga., 3.625"x 1.375" Metal C-stud	16	20 Fastener Load: 18	24 Fastener Load: 22	30 Fastener Load: 27	24 Fastener Load: 22
9 1/4" Lap Siding	5/16	9.25	1 5/8", steel, self-tapping screw, 3/8" phillips head, ITW Buildex "Rock-On" S-12 #2159500	Blind screwed	Min. 20 ga., 3.625"x 1.375" Metal C-stud	16	19 Fastener Load: 18	23 Fastener Load: 22	29 Fastener Load: 27	23 Fastener Load: 22
9 1/4" Lap Siding	5/16	9.25	1 5/8", steel, self-tapping screw, 3/8" phillips head, ITW Buildex "Rock-On" S-12 #2159500	Face screwed	Min. 20 ga., 3.625"x 1.375" Metal C-stud	24	16 Fastener Load: 22	19 Fastener Load: 26	24 Fastener Load: 33	19 Fastener Load: 26
9 1/4" Lap Siding	5/16	9.25	1 5/8", steel, self-tapping screw, 3/8" phillips head, ITW Buildex "Rock-On" S-12 #2159500	Blind screwed	Min. 20 ga., 3.625"x 1.375" Metal C-stud	24	16 Fastener Load: 21	19 Fastener Load: 25	24 Fastener Load: 32	19 Fastener Load: 25
9 1/4" Lap Siding	5/16	9.25	1 5/8", steel, self-tapping screw, 3/8" phillips head, ITW Buildex "Rock-On" S-12 #2159500	Blind screwed	Min. 16 ga., 3.625"x 1.375" Metal C-stud	16	32 Fastener Load: 29	38 Fastener Load: 35	48 Fastener Load: 44	38 Fastener Load: 35
9 1/4" Lap Siding	5/16	9.25	1 5/8", steel, self-tapping screw, 3/8" phillips head, ITW Buildex "Rock-On" S-12 #2159500 into OSB ³	Blind screwed	Min. 20 ga., 3.625"x 1.375" Metal C-stud w/ 7/16" OSB ³	16	23 Fastener Load: 21	28 Fastener Load: 25	35 Fastener Load: 31	28 Fastener Load: 25
9 1/4" Lap Siding	5/16	9.25	1 5/8", steel, self-tapping screw, 3/8" phillips head, ITW Buildex "Rock-On" S-12 #2159500 into OSB ³	Blind screwed	Min. 20 ga., 3.625"x 1.375" Metal C-stud w/ 7/16" OSB ³	24	22 Fastener Load: 30	27 Fastener Load: 36	34 Fastener Load: 45	27 Fastener Load: 36
9 1/4" Lap Siding	5/16	9.25	.100"x1.5" Knurled pins, .3125" head, ET&F #AGS-100-0150NA	Blind nailed	Min. 20 ga., 3.625"x 1.375" Metal C-stud w/ 7/16" OSB ³	16	22 Fastener Load: 20	27 Fastener Load: 24	34 Fastener Load: 30	27 Fastener Load: 24

TABLE 3 - ALLOWABLE WIND PRESSURES AND REQUIRED FASTENER SCHEDULE (Continued)

PRODUCT	PRODUCT DIMS (in.)		FASTENER TYPE	FASTENING METHOD ¹	FRAMING TYPE	FRAMING SPACING (in)	ALLOWABLE WIND PRESSURES (lb/ft ²) AND FASTENER LOAD ² (pounds)			
	Thick.	Width					Uniform Building Code	BOCA National Building Code	Standard Building Code	International Building Code
9 1/4" Lap Siding	5/16	9.25	.100"x1.5" Knurled pins, .3125" head, ET&F #AGS-100-0150NA	Blind nailed	Min. 20 ga., 3.625"x 1.375" Metal C-stud w/ 7/16" OSB ³	24	20 Fastener Load: 27	24 Fastener Load: 32	30 Fastener Load: 41	24 Fastener Load: 32
8 1/4" Lap Siding	5/16	8.25	7d nails, HD Galv., Maze Nails #225HD-022	Face nailed	2x4 #2 SPF	16	60 Fastener Load: 47	73 Fastener Load: 56	91 Fastener Load: 70	73 Fastener Load: 56
8 1/4" Lap Siding	5/16	8.25	7d nails, HD Galv., Maze Nails #225HD-022	Face nailed	2x4 #2 SPF	24	44 Fastener Load: 51	52 Fastener Load: 61	65 Fastener Load: 76	52 Fastener Load: 61
8 1/4" Lap Siding	5/16	8.25	6d 2" Roofing nails, HD Galv., Maze Nails #HD-105	Blind nailed	2x4 #2 SPF	16	41 Fastener Load: 32	49 Fastener Load: 38	62 Fastener Load: 48	49 Fastener Load: 38
8 1/4" Lap Siding	5/16	8.25	6d 2" Roofing nails, HD Galv., Maze Nails #HD-105	Blind nailed	2x4 #2 SPF	24	32 Fastener Load: 37	38 Fastener Load: 44	48 Fastener Load: 56	38 Fastener Load: 44
8 1/4" Lap Siding	5/16	8.25	6d nails, HD Galv., Maze Nails #200HD-018	Blind nailed w/ Off-Stud Joiner	2x4 #2 SPF	16	37 Fastener Load: 28	44 Fastener Load: 34	55 Fastener Load: 42	44 Fastener Load: 34
8 1/4" Lap Siding	5/16	8.25	6d nails, HD Galv., Maze Nails #200HD-018	Blind nailed	2x4 #2 SPF	16	32 Fastener Load: 25	38 Fastener Load: 30	48 Fastener Load: 37	38 Fastener Load: 30
8 1/4" Lap Siding	5/16	8.25	1 5/8", steel, self-tapping screw, 3/8" phillips head, ITW Buildex "Rock-On" S-12 #2159500	Blind screwed	Min. 20 ga., 3.625"x 1.375" Metal C-stud	16	19 Fastener Load: 14	22 Fastener Load: 17	28 Fastener Load: 22	22 Fastener Load: 17
8 1/4" Lap Siding	5/16	8.25	1 5/8", steel, self-tapping screw, 3/8" phillips head, ITW Buildex "Rock-On" S-12 #2159500	Blind screwed	Min. 20 ga., 3.625"x 1.375" Metal C-stud	24	13 Fastener Load: 15	15 Fastener Load: 18	19 Fastener Load: 22	15 Fastener Load: 18
8 1/4" Lap Siding	5/16	8.25	.100"x1.5" Knurled pins, .3125" head, ET&F #AGS-100-0150NA	Face nailed	Min. 20 ga., 3.625"x 1.375" Metal C-stud	16	24 Fastener Load: 19	29 Fastener Load: 23	36 Fastener Load: 29	29 Fastener Load: 23
8 1/4" Lap Siding	5/16	8.25	.100"x1.5" Knurled pins, .3125" head, ET&F #AGS-100-0150NA	Face nailed	Min. 20 ga., 3.625"x 1.375" Metal C-stud	24	16 Fastener Load: 19	19 Fastener Load: 23	24 Fastener Load: 28	19 Fastener Load: 23
8 1/4" Lap Siding	5/16	8.25	.100"x1.5" Knurled pins, .3125" head, ET&F #AGS-100-0150NA	Blind nailed	Min. 20 ga., 3.625"x 1.375" Metal C-stud	16	24 Fastener Load: 19	29 Fastener Load: 23	36 Fastener Load: 29	29 Fastener Load: 23
8 1/4" Lap Siding	5/16	8.25	.100"x1.5" Knurled pins, .3125" head, ET&F #AGS-100-0150NA	Blind nailed	Min. 20 ga., 3.625"x 1.375" Metal C-stud	24	16 Fastener Load: 19	19 Fastener Load: 22	24 Fastener Load: 28	19 Fastener Load: 22
7 1/4" Lap Siding	5/16	7.25	6d box nails	Face nailed	2x4 #2 SPF	16	46 Fastener Load: 32	55 Fastener Load: 38	69 Fastener Load: 48	55 Fastener Load: 38
7 1/4" Lap Siding	5/16	7.25	6d box nails	Blind nailed	2x4 #2 SPF	16	22 Fastener Load: 16	27 Fastener Load: 19	34 Fastener Load: 23	26 Fastener Load: 19
7 1/4" Lap Siding	5/16	7.25	6d box nails	Face nailed	2x4 #2 SPF	24	34 Fastener Load: 36	41 Fastener Load: 43	52 Fastener Load: 54	41 Fastener Load: 43
7 1/4" Lap Siding	5/16	7.25	1 3/4" Roofing nails	Blind nailed	2x4 #2 SPF	16	32 Fastener Load: 22	39 Fastener Load: 27	48 Fastener Load: 33	38 Fastener Load: 26

TABLE 3 - ALLOWABLE WIND PRESSURES AND REQUIRED FASTENER SCHEDULE (Continued)

PRODUCT	PRODUCT DIMS (in.)		FASTENER TYPE	FASTENING METHOD ¹	FRAMING TYPE	FRAMING SPACING (in)	ALLOWABLE WIND PRESSURES (lb/ft ²) AND FASTENER LOAD ² (pounds)			
	Thick.	Width					Uniform Building Code	BOCA National Building Code	Standard Building Code	International Building Code
7 1/4" Lap Siding	5/16	7.25	6d 2" Roofing nails, HD Galv., Maze Nails #HD-105	Blind nailed	2x4 #2 SPF	16	64 Fastener Load: 43	77 Fastener Load: 52	97 Fastener Load: 65	77 Fastener Load: 52
7 1/4" Lap Siding	5/16	7.25	6d 2" Roofing nails, HD Galv., Maze Nails #HD-105	Blind nailed	2x4 #2 SPF	24	44 Fastener Load: 44	53 Fastener Load: 53	66 Fastener Load: 66	53 Fastener Load: 53
7 1/4" Lap Siding	5/16	7.25	6d nails, HD Galv., Maze Nails #200HD-018	Blind nailed	2x4 #2 SPF	24	24 Fastener Load: 25	29 Fastener Load: 30	36 Fastener Load: 38	29 Fastener Load: 30
7 1/4" Lap Siding	5/16	7.25	1 5/8", steel, self-tapping screw, 3/8" phillips head, ITW Buildex "Rock-On" S-12 #2159500	Blind screwed	Min. 20 ga., 3.625"x 1.375" Metal C-stud	16	20 Fastener Load: 13	24 Fastener Load: 16	30 Fastener Load: 20	24 Fastener Load: 16
7 1/4" Lap Siding	5/16	7.25	1 5/8", steel, self-tapping screw, 3/8" phillips head, ITW Buildex "Rock-On" S-12 #2159500	Blind screwed	Min. 20 ga., 3.625"x 1.375" Metal C-stud	24	19 Fastener Load: 19	22 Fastener Load: 22	28 Fastener Load: 28	22 Fastener Load: 22
7 1/4" Lap Siding	5/16	7.25	.100"x1.5" Knurled pins, .3125" head, ET&F #AGS-100-0150NA	Face nailed	Min. 20 ga., 3.625"x 1.375" Metal C-stud	16	22 Fastener Load: 15	27 Fastener Load: 18	33 Fastener Load: 22	27 Fastener Load: 18
7 1/4" Lap Siding	5/16	7.25	.100"x1.5" Knurled pins, .3125" head, ET&F #AGS-100-0150NA	Blind nailed	Min. 20 ga., 3.625"x 1.375" Metal C-stud	16	16 Fastener Load: 11	20 Fastener Load: 13	25 Fastener Load: 17	20 Fastener Load: 13
7 1/4" Lap Siding	5/16	7.25	.100"x1.5" Knurled pins, .3125" head, ET&F #AGS-100-0150NA	Face nailed	Min. 20 ga., 3.625"x 1.375" Metal C-stud	24	20 Fastener Load: 20	25 Fastener Load: 25	31 Fastener Load: 31	25 Fastener Load: 25
7 1/4" Lap Siding	5/16	7.25	.100"x1.5" Knurled pins, .3125" head, ET&F #AGS-100-0150NA	Blind nailed	Min. 20 ga., 3.625"x 1.375" Metal C-stud	24	16 Fastener Load: 16	20 Fastener Load: 20	24 Fastener Load: 24	20 Fastener Load: 20
6 1/4" Lap Siding	5/16	6.25	6d box nails	Face nailed	2x4 #2 SPF	16	53 Fastener Load: 31	64 Fastener Load: 37	80 Fastener Load: 46	64 Fastener Load: 37
6 1/4" Lap Siding	5/16	6.25	6d box nails	Blind nailed	2x4 #2 SPF	16	32 Fastener Load: 19	39 Fastener Load: 23	48 Fastener Load: 28	38 Fastener Load: 23
6 1/4" Lap Siding	5/16	6.25	6d box nails	Face nailed	2x4 #2 SPF	24	38 Fastener Load: 33	45 Fastener Load: 40	56 Fastener Load: 56	46 Fastener Load: 40
6 1/4" Lap Siding	5/16	6.25	1 3/4" Roofing nails	Blind nailed	2x4 #2 SPF	16	43 Fastener Load: 38	52 Fastener Load: 46	65 Fastener Load: 57	52 Fastener Load: 46
6 1/4" Lap Siding	5/16	6.25	6d nails, HD Galv., Maze Nails #200HD-018	Blind nailed	2x4 #2 SPF	24	32 Fastener Load: 28	38 Fastener Load: 34	48 Fastener Load: 42	38 Fastener Load: 34
6 1/4" Lap Siding	5/16	6.25	6d 2" Roofing nails, HD Galv., Maze Nails #HD-105	Blind nailed	2x4 #2 SPF	16	40 Fastener Load: 23	48 Fastener Load: 28	60 Fastener Load: 35	48 Fastener Load: 28
6 1/4" Lap Siding	5/16	6.25	6d 2" Roofing nails, HD Galv., Maze Nails #HD-105	Blind nailed	2x4 #2 SPF	24	45 Fastener Load: 37	54 Fastener Load: 45	67 Fastener Load: 56	54 Fastener Load: 45
6 1/4" Lap Siding	5/16	6.25	1 5/8", steel, self-tapping screw, 3/8" phillips head, ITW Buildex "Rock-On" S-12 #2159500	Blind screwed	Min. 20 ga., 3.625"x 1.375" Metal C-stud	16	23 Fastener Load: 13	28 Fastener Load: 16	35 Fastener Load: 20	28 Fastener Load: 16
6 1/4" Lap Siding	5/16	6.25	1 5/8", steel, self-tapping screw, 3/8" phillips head, ITW Buildex "Rock-On" S-12 #2159500	Blind screwed	Min. 20 ga., 3.625"x 1.375" Metal C-stud	24	19 Fastener Load: 17	23 Fastener Load: 20	29 Fastener Load: 26	23 Fastener Load: 20

TABLE 3 - ALLOWABLE WIND PRESSURES AND REQUIRED FASTENER SCHEDULE (Continued)

PRODUCT	PRODUCT DIMS (in.)		FASTENER TYPE	FASTENING METHOD ¹	FRAMING TYPE	FRAMING SPACING (in)	ALLOWABLE WIND PRESSURES (lb/ft ²) AND FASTENER LOAD ² (pounds)			
	Thick.	Width					Uniform Building Code	BOCA National Building Code	Standard Building Code	International Building Code
6 1/4" Lap Siding	5/16	6.25	.100"x1.5" Knurled pins, .3125" head, ET&F #AGS-100-0150NA	Blind nailed	Min. 20 ga., 3.625"x 1.375" Metal C-stud	16	23 Fastener Load: 13	28 Fastener Load: 16	35 Fastener Load: 20	28 Fastener Load: 16
6 1/4" Lap Siding	5/16	6.25	.100"x1.5" Knurled pins, .3125" head, ET&F #AGS-100-0150NA	Face nailed	Min. 20 ga., 3.625"x 1.375" Metal C-stud	16	16 Fastener Load: 9	19 Fastener Load: 11	24 Fastener Load: 14	19 Fastener Load: 11
6 1/4" Lap Siding	5/16	6.25	.100"x1.5" Knurled pins, .3125" head, ET&F #AGS-100-0150NA	Face nailed	Min. 20 ga., 3.625"x 1.375" Metal C-stud	24	17 Fastener Load: 14	21 Fastener Load: 17	26 Fastener Load: 22	21 Fastener Load: 17
6 1/4" Lap Siding	5/16	6.25	.100"x1.5" Knurled pins, .3125" head, ET&F #AGS-100-0150NA	Blind nailed	Min. 20 ga., 3.625"x 1.375" Metal C-stud	24	17 Fastener Load: 14	20 Fastener Load: 17	25 Fastener Load: 21	20 Fastener Load: 17
5 1/4" Lap Siding	5/16	5.25	7d nails, HD Galv., Maze Nails #225HD-022	Face nailed	2x4 #2 SPF	16	48 Fastener Load: 21	58 Fastener Load: 25	72 Fastener Load: 32	58 Fastener Load: 25
5 1/4" Lap Siding	5/16	5.25	7d nails, HD Galv., Maze Nails #225HD-022	Face nailed	2x4 #2 SPF	24	38 Fastener Load: 25	46 Fastener Load: 30	57 Fastener Load: 38	46 Fastener Load: 30
5 1/4" Lap Siding	5/16	5.25	6d nails, HD Galv., Maze Nails #200HD-018	Blind nailed	2x4 #2 SPF	16	44 Fastener Load: 19	53 Fastener Load: 23	66 Fastener Load: 29	53 Fastener Load: 23
5 1/4" Lap Siding	5/16	5.25	6d nails, HD Galv., Maze Nails #200HD-018	Blind nailed	2x4 #2 SPF	24	31 Fastener Load: 21	37 Fastener Load: 25	47 Fastener Load: 32	37 Fastener Load: 25
5 1/4" Lap Siding	5/16	5.25	8d nails, HD Galv., Maze Nails #C-CEM8	Face nailed	2x4 #2 SPF	16	53 Fastener Load: 23	64 Fastener Load: 28	80 Fastener Load: 35	64 Fastener Load: 28
5 1/4" Lap Siding	5/16	5.25	8d nails, HD Galv., Maze Nails #C-CEM8	Blind nailed	2x4 #2 SPF	16	62 Fastener Load: 27	74 Fastener Load: 32	93 Fastener Load: 41	74 Fastener Load: 32
5 1/4" Lap Siding	5/16	5.25	8d nails, HD Galv., Maze Nails #C-CEM8	Face nailed	2x4 #2 SPF	24	45 Fastener Load: 30	54 Fastener Load: 36	68 Fastener Load: 45	54 Fastener Load: 36
5 1/4" Lap Siding	5/16	5.25	8d nails, HD Galv., Maze Nails #C-CEM8	Blind nailed	2x4 #2 SPF	24	33 Fastener Load: 22	40 Fastener Load: 26	50 Fastener Load: 33	40 Fastener Load: 26
5 1/4" Lap Siding	5/16	5.25	6d 2" Roofing nails, HD Galv., Maze Nails #HD-105	Blind nailed	2x4 #2 SPF	16	40 Fastener Load: 18	48 Fastener Load: 22	60 Fastener Load: 27	48 Fastener Load: 22
5 1/4" Lap Siding	5/16	5.25	6d 2" Roofing nails, HD Galv., Maze Nails #HD-105	Blind nailed	2x4 #2 SPF	24	37 Fastener Load: 25	44 Fastener Load: 30	56 Fastener Load: 38	44 Fastener Load: 30
5 1/4" Lap Siding	5/16	5.25	.100"x1.5" Knurled pins, .3125" head, ET&F #AGS-100-0150NA	Face nailed	Min. 20 ga., 3.625"x 1.375" Metal C-stud	16	16 Fastener Load: 7	19 Fastener Load: 9	24 Fastener Load: 11	19 Fastener Load: 9
5 1/4" Lap Siding	5/16	5.25	.100"x1.5" Knurled pins, .3125" head, ET&F #AGS-100-0150NA	Blind nailed	Min. 20 ga., 3.625"x 1.375" Metal C-stud	16	26 Fastener Load: 11	31 Fastener Load: 13	39 Fastener Load: 17	31 Fastener Load: 13
5 1/4" Lap Siding	5/16	5.25	.100"x1.5" Knurled pins, .3125" head, ET&F #AGS-100-0150NA	Face nailed	Min. 20 ga., 3.625"x 1.375" Metal C-stud	24	19 Fastener Load: 13	23 Fastener Load: 16	29 Fastener Load: 20	23 Fastener Load: 16

TABLE 3 - ALLOWABLE WIND PRESSURES AND REQUIRED FASTENER SCHEDULE (Continued)

PRODUCT	PRODUCT DIMS (in.)		FASTENER TYPE	FASTENING METHOD ¹	FRAMING TYPE	FRAMING SPACING (in)	ALLOWABLE WIND PRESSURES (lbf/ft ²) AND FASTENER LOAD ² (pounds)			
	Thick.	Width					Uniform Building Code	BOCA National Building Code	Standard Building Code	International Building Code
5 1/4" Lap Siding	5/16	5.25	.100"x1.5" Knurled pins, .3125" head, ET&F #AGS-100-0150NA	Blind nailed	Min. 20 ga., 3.625"x 1.375" Metal C-stud	24	19 Fastener Load: 13	23 Fastener Load: 16	29 Fastener Load: 20	23 Fastener Load: 16
5 1/4" Lap Siding	5/16	5.25	1 5/8", steel, self-tapping screw, 3/8" phillips head, ITW Buildex "Rock-On" S-12 #2159500	Face screwed	Min. 20 ga., 3.625"x 1.375" Metal C-stud	16	24 Fastener Load: 11	29 Fastener Load: 13	36 Fastener Load: 17	29 Fastener Load: 13
5 1/4" Lap Siding	5/16	5.25	1 5/8", steel, self-tapping screw, 3/8" phillips head, ITW Buildex "Rock-On" S-12 #2159500	Blind screwed	Min. 20 ga., 3.625"x 1.375" Metal C-stud	16	20 Fastener Load: 9	24 Fastener Load: 11	30 Fastener Load: 13	24 Fastener Load: 11
5 1/4" Lap Siding	5/16	5.25	1 5/8", steel, self-tapping screw, 3/8" phillips head, ITW Buildex "Rock-On" S-12 #2159500	Blind screwed	Min. 20 ga., 3.625"x 1.375" Metal C-stud	24	19 Fastener Load: 13	23 Fastener Load: 15	29 Fastener Load: 19	23 Fastener Load: 15
Shapes	5/16	16	6d Ring shank nail, HD Galv., Maze Nails #C-S205-A	Blind Nailed	2x4 #2 SPF	24	28 Fastener Load: 32	34 Fastener Load: 38	42 Fastener Load: 48	34 Fastener Load: 38
Shapes	5/16	16	6d Ring shank nail, HD Galv., Maze Nails #C-S205-A	Blind Nailed	2x4 #2 SPF w/ 5/8" OSB ⁴	16	89 Fastener Load: 69	107 Fastener Load: 83	134 Fastener Load: 104	107 Fastener Load: 83
Shapes	5/16	16	.100"x1.5" Knurled pins, .3125" head, ET&F #AGS-100-0150NA	Blind nailed	Min. 20 ga., 3.625"x 1.375" Metal C-stud	16	23 Fastener Load: 18	28 Fastener Load: 22	35 Fastener Load: 27	28 Fastener Load: 22
Shapes	5/16	16	.100"x1.5" Knurled pins, .3125" head, ET&F #AGS-100-0150NA	Blind nailed	Min. 20 ga., 3.625"x 1.375" Metal C-stud	24	18 Fastener Load: 21	22 Fastener Load: 25	27 Fastener Load: 32	22 Fastener Load: 25
Shapes	5/16	16	1 1/2" Roofing nail	Blind Nailed	2x4 #2 SPF w/ 5/8" OSB ⁴	24	67 Fastener Load: 77	80 Fastener Load: 92	100 Fastener Load: 116	80 Fastener Load: 92

For SI: 1 inch = 25.4mm, 1 pound/foot² = 47.8803 kPa: 1 pound = 4.448N.

¹ See Figure 2 of this report for a description of face and blind nailing.

² Fastener load represents the withdrawal load exerted on the fastener at the specified allowable wind pressure.

³ For these assemblies the walls shall be solidly sheathed with minimum 7/16-inch OSB structural wood panels complying with DOC PS-2 and installed with 8d nails spaced a maximum of 4-inches o.c. on the edges and a maximum of 8-inches o.c. in the field.

⁴ For these assemblies the walls shall be solidly sheathed with minimum 5/8-inch OSB structural wood panels complying with DOC PS-2 and installed with 8d nails spaced a maximum of 4-inches o.c. on the edges and a maximum of 8-inches o.c. in the field.

TABLE 4—ALLOWABLE FASTENER WITHDRAWAL CAPACITY (pounds)^{1,2,3}

FASTENER	PRODUCT APPLICATION		FRAMING MATERIAL ⁴					
			Spruce-Pine-Fir, 0.42 s.g.	Hem-Fir, 0.46 s.g.	Douglas Fir-Larch, 0.50 s.g.	Southern Pine, 0.55 s.g.	20 ga Steel	⁷ / ₁₆ " OSB
6d box nail	Lap siding - blind nailed		43.2	54.0	64.8	83.7	—	—
	Panel		43.2	54.0	64.8	83.7	—	—
8d box nail	Lap siding - face nailed		54.0	66.0	84.0	115.0	—	—
	Panel		63.0	77.0	98.0	125.0	—	—
1 ³ / ₄ " roofing nail	Lap siding - blind nailed		43.7	54.1	67.9	86.3	—	—
	Panel		—	—	—	—	—	—
6d nail Maze nails #200 HD-018	Lap siding - blind nailed		40.2	—	—	—	—	16.0
	Panel		40.2	—	—	—	—	16.0
7d nail Maze nails #225 HD-022	Lap siding - face nailed		38.8	—	—	—	—	11.0
	Panel		38.8	—	—	—	—	11.0
8d nail Maze nails #C-CEM8	Lap siding	Face nailed	45.3	—	—	—	—	—
		Blind nailed	45.3	—	—	—	—	—
	Panel		45.3	—	—	—	—	—
6D roofing nail Maze nails #HD-105	Lap siding - blind nailed		59.3	—	—	—	—	28.0
	Panel		59.3	—	—	—	—	28.0
1 ¹ / ₂ " ring shank roofing nails Maze nails #R103-A	Lap siding - blind nailed		—	—	—	—	—	13.7
	Panel		—	—	—	—	—	13.7
6d ring shank Maze nails #C-S205A	Lap siding - blind nailed		54.5	—	—	—	—	16.5
	Panel		54.5	—	—	—	—	16.5
0.100" x 1 ¹ / ₂ " pins ET&F #AGS-100-0150NA	Lap siding	Face nailed	—	—	—	—	35.0	—
		Blind nailed	—	—	—	—	35.0	—
	Panel		—	—	—	—	35.0	—
1 ⁵ / ₈ " screws ITW Buildex "Rock-On" S-12	Lap siding - blind nailed		—	—	—	—	59.3	—
	Panel		—	—	—	—	59.3	—
1 ⁵ / ₈ " screws ITW Buildex "Rock On" Hi-Lo	Lap siding - blind nailed		—	—	—	—	—	50.8
	Panel		—	—	—	—	—	50.8

For SI: 1 inch = 25.4 mm, 1 lbf = 4.448N.

¹Where nonstructural sheathing is located under the siding, the length of the fastener shall be increased an equivalent length so as to provide the required 1¹/₄-inch fastener penetration.

²6d box and 8d box nails are hot-dipped galvanized box nails. They are minimum 1³/₄-inch-long, stainless steel or hot-dipped galvanized nails having a head diameter of ³/₈ inch.

³The allowable fastener withdrawal value specified above shall be greater than or equal to the minimum fastener load specified in Table 3 of this report.

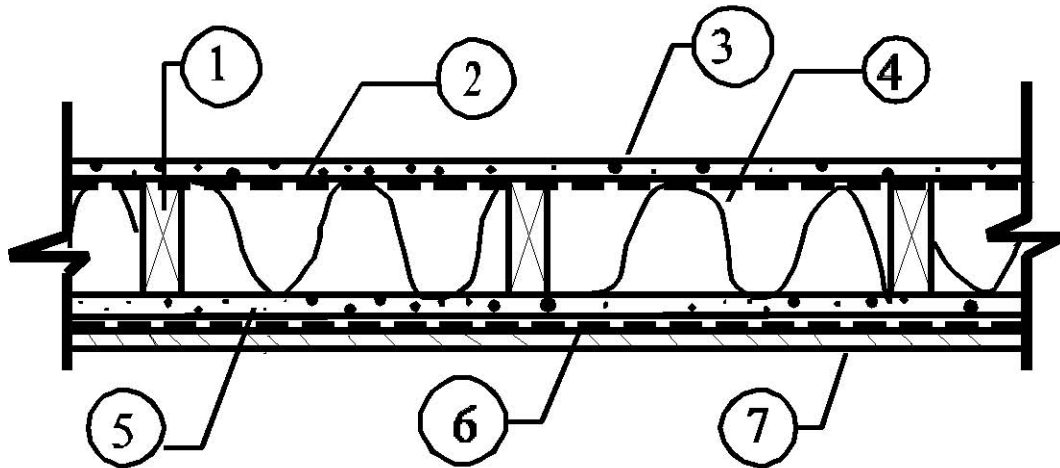

- ITEM 1:** Allowable axial load for a wall assembly constructed with WeatherBoards™ FiberCement Lap Siding shall be 49 percent or less of the allowable axial design stress calculated in accordance with the *National Design Specification for Wood Construction* (This equates to 1,200 lbs, (5335 N) per 2x4 or 228.5 psi (1.57 N/mm²) when No. 2 Southern Pine studs are used in the construction of a wall having an unbraced height of 9 ft (2.7 m)). Allowable axial load for a wall assembly constructed with WeatherBoards™ FiberCement Vertical Siding shall be 73.4 percent or less of the allowable axial design stress calculated in accordance with the *National Design Specification for Wood Construction* (This equates to 1800 lbs (8000 N) per 2x4 stud or 342.9 psi (2.37 N/mm²) when No. 2 Southern Pine studs are used in construction of a wall having an unbraced height of 9 ft (2.7 m)).
- ITEM 2:** Continuous vapor barrier in accordance with the applicable code and the manufacturer's instructions.
- ITEM 3:** Interior side of wall assembly shall be covered with ⁵/₈-inch thick ASTM C36-95b Type X gypsum wall board. Wall board shall be fastened to wood framing with 1⁵/₈-inch long No. 6 Type W drywall screws spaced 8 inches on center at the edges and 12 inches in center in the field. All screw heads covered with joint compound and all wallboard joints shall be covered with joint compound and taped and treated with joint compound. Joint compound shall comply with ASTM C474 and C475.
- ITEM 4:** Insulation shall be provided and shall be either mineral wool or fiberglass. Mineral wool shall have a nominal density of 2.5 lbs/ft³. The fiberglass shall be R13. Batts shall be 16 inches wide.
- ITEM 5:** Exterior side of wall assembly shall be covered with ⁵/₈-inch thick ASTM C79-95 Type X gypsum sheathing. Gypsum sheathing shall be fastened to wood framing with 1⁵/₈-inch long No. 6 Type S drywall screws spaced 8 inches on center at the edges and 12 inches on center in the field.
- ITEM 6:** Weather-resistive barrier in accordance with this report and the applicable code.
- ITEM 7:** Exterior wall covering shall be either WeatherBoards™ FiberCement Lap Siding or WeatherBoards™ FiberCement Vertical Siding. Where Lap siding is utilized the overlap shall be a minimum of 1¹/₄ inches and face fastened with 2¹/₂-inch-long double hot-dipped galvanized roofing fasteners with a head diameter of ³/₈ inch. The fastening schedule for WeatherBoards™ FiberCement Vertical Siding shall be a maximum of 6 inches o.c. at the edges and 12 inches o.c. in the field with 8d common nails.

For SI: 1 inch = 25.4 mm; 1 lbf = 4.448 N.

FIGURE 1—ONE-HOUR FIRE-RESISTANCE-RATED WALL ASSEMBLY FOR WEATHERBOARDS™ FIBERCEMENT LAP AND VERTICAL SIDING

face nail option

blind nail option

**1 1/4" overlap
minimum**

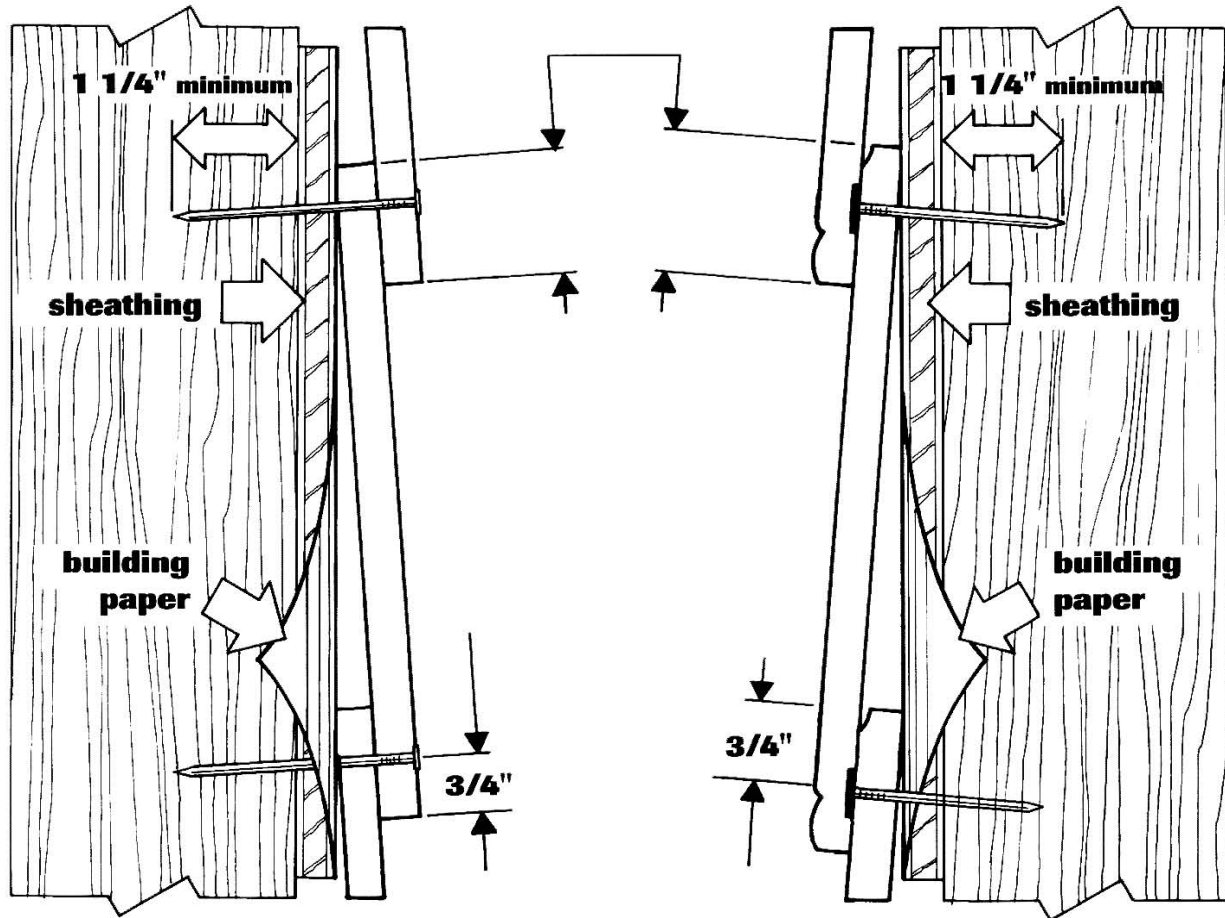

NOTE:

¹See Section 4.2.2 and Table 3 of this report for the fastening requirements of lap siding.

²For SI: 1 inch = 25.4 mm.

FIGURE 2—WEATHERBOARDS™ FIBERCEMENT LAP SIDING INSTALLATION DIAGRAMS