

Installation Instructions Cedar Impressions® Half-Round Shingles

These instructions describe and illustrate the steps involved in installing CertainTeed siding and trim. Their purpose is to provide detailed information and how-to tips that will simplify the installation process. CertainTeed shall not accept any liability or responsibility under its written warranty for failure caused by application that does not meet our minimum requirements for proper installation. These requirements are outlined throughout the *CertainTeed Installation Guide (CTS205)*. Any deviations from these requirements should be approved in writing by CertainTeed Corporation.

Important

This product is not designed for roof applications. It is designed solely for installation on vertical surfaces.

Panels must be installed with nails over a solid substrate with nail holding strength such as plywood, oriented strand board, or existing wood siding (minimum 7/16" thick). This product cannot be installed with staples.

NOTE: Each panel must be nailed through the round hole in the center of the nail hem to control the direction of normal expansion and contraction. If you are installing a partial panel and the center nail hole has been cut off, drill a nail hole in the center of the nail hem of the cut panel and nail through it.

Panel Spacing at Different Temperatures

As with any plastic siding, Cedar Impressions expands and contracts with changes in temperature. For this reason, it is important that you space the panels according to the panel temperature at the time of installation. Failure to provide the proper spacing according to these temperature ranges may result in gaps that are too large or too small, thereby creating the potential for side lock tabs disengaging, panel distortion, or buckling. Spacing of panels previously installed at a different temperature does not require adjustment.

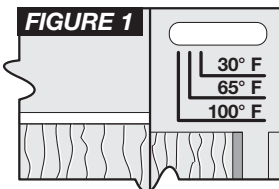

Each panel has indicator lines that serve as guides for proper spacing between the panels. The indicator lines are on the upper left-hand corner. Before

you install Half-Round Shingles, make sure the panels are acclimated to the ambient temperature. As the ambient temperature changes during the day, it may be necessary to adjust the panel spacing to reflect the change in the panel temperature.

Panel Temperature	Temperature Indicator Lines
30° to 40°	Set to 30 line
41° to 55°	Set halfway between 30 and 65 lines
56° to 75°	Set to 65 line
76° to 90°	Set halfway between 65 and 100 lines
91° to 100°	Set to 100 line

First course

Strike a level line around the house and install Shingle Starter. An alternative method of starting Half-Rounds is to use J-channel in place of starter strip to receive the bottom edge of the panel. To use this method, the rounded portion of the panel must be removed below the locking leg to create a continuous straight edge. When using J-channel as a starter, leave 1/4" between the siding panel and pocket.

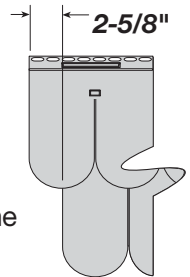
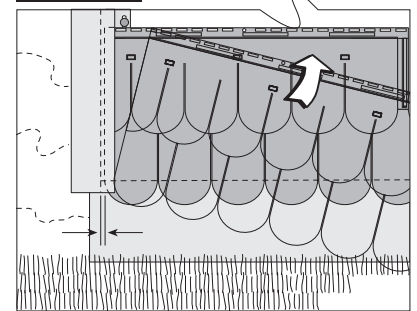

FIGURE 2

1) Remove 2-5/8" from the left side of the upper panel course, leaving a 90° left side edge, as shown in figure 2.

2) Starting on the left side of the wall, hook the bottom edge of the panel into the starter strip and slide the panel into the cornerpost or receiving channel (figure 3). Leave 1/4" space between the panel and the inside wall of the cornerpost for expansion.

FIGURE 3



3) Fasten the panel to the wall by first nailing through the round center hole of the nailing hem at the top of the panel. Then fasten the rest of the panel by nailing through the centers of the remaining nail slots a maximum of every 8" to 16" on center. Provide 1/8" to 1/16" between the nail head and the panel to allow freedom of movement during normal expansion and contraction. Failure to provide this space between nail head and panel will cause the panel to buckle. Do not put a nail into the far right slot until the overlapping panel is positioned for installation.

4) Install the next panel by using a dual motion of hooking into the starter strip and sliding over the previous panel. This will ensure a proper lap (figure 4).

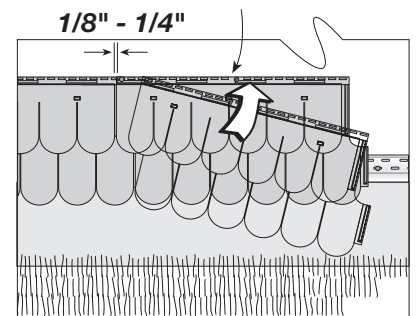

FIGURE 4

5) Position the overlapping panel so that there is 1/8" to 1/4" between the panels, depending on the panel temperature at the time of installation. The spacing may appear larger or smaller than the spaces between the shingles on the panel. This is normal and necessary in order to allow for expansion and contraction.

- 6) Nail in the center of the far left slot of the overlapping panel.
- 7) Continue to install the remaining panels of the first course as described in steps 3 through 6.

Second course

- 8) Remove 13-1/4" of the left side measured from the upper panel, cutting straight through the lower panel course as shown in figure 5. (Note the small mark on the face of the panel.) Drill a 3/16" hole in the center of the nail hem and nail the siding through this hole to control the direction of expansion and contraction. The 13-1/4" spacing provides the farthest separation of overlapping courses.
- 9) For easier application of complete panels, 1/4" vertical lines have been added to the top edge of the nail flange for quick initial alignment. Simply align the right edge of the upper panel with one of the vertical alignment marks on the lower course. However, always use the temperature indicator marks on the right side of the upper panels for final alignment. Continue to repeat steps 4-7.

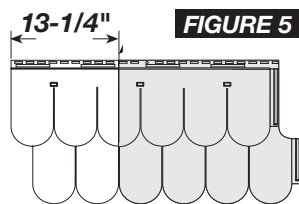

FIGURE 5

- 10) Cedar Impressions Half-Rounds may also be installed by sliding the right panel up while ensuring the side lock tabs engage with the flange of the left panel (figure 6).

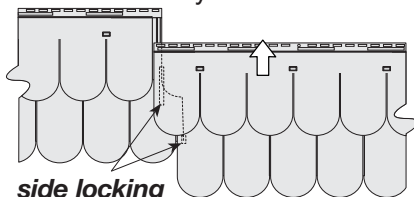

FIGURE 6

This method is useful when installing panels into cornerposts and J-channel around windows and doors.

- 11) Continue to stagger the panel courses according to steps 1 and 8, alternating each time to ensure a random shingle pattern up the wall.

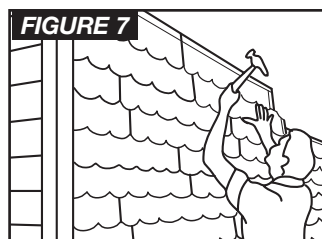

FIGURE 7

Installing under a window or opening

Install Cedar Impressions undersill trim. Cut the panel to fit under the window. Drill a 3/16" hole in the center of the nail hem. Using a snap lock punch, raise tab faces on the outside of the panel 1/4" from the trimmed edge, 6" apart. Lock the panel into the previous course, and center nail the siding through the 3/16" hole drilled earlier. Lock the panel into place (figure 8).

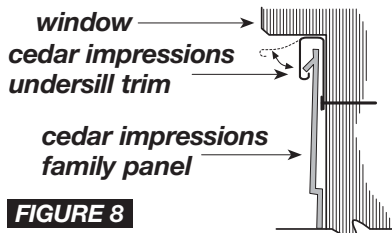

FIGURE 8

Installing over a window or opening

To install siding over a window, measure from the lock tab of the course below the window top to the top of the window. Add 3/4". Cut the panel to this dimension. This will allow the panel to be lowered down far enough to engage the locking tabs of the lower panel. After it is positioned into the locked position, the cut edge will still be 1/4" below the top of the J-channel.

Finishing the top course

To finish the top course of siding, attach cornice receiver to the top of the wall under the eave or soffit. Trim the top panel to within 1/4" of the cornice receiver. Using a nail slot punch, punch nail slots 1/4" from the trimmed edge, 16" apart. Nail off the top course, and snap the cornice molding into the cornice receiver (figure 9).

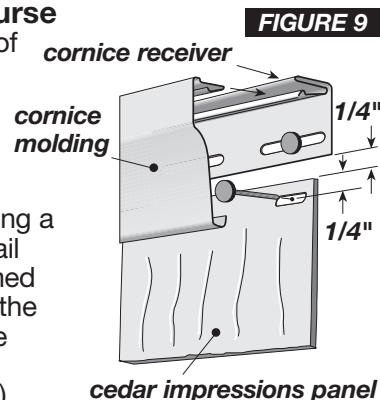

FIGURE 9

An alternate method is to use J-channel and furring strips.

Half-Round Shingles in Gable Ends

NOTE: These instructions are for an enclosed gable started with a J-channel. Half-Rounds can also be started with starter strip. This is an example only!

Installing receiving channels

Frame the border area with 3/4" J-channel. Nail it in place loosely. Miter the joints accordingly. You also can use 3-1/2" or 5" lineals to frame gable ends and the gable base.

Cut enough J-channel to span the base of the gable, then secure it in place.

Making the starter course

Gable installations properly terminate with a single round at the peak. To create this effect, you usually have to adjust the height of the starter course.

To determine the height of the starter course, calculate the number of rows required to complete the gable.

Use the following formula:

$$\text{Gable height (inches)} \div 12.5 \text{ (face exposure)} = \text{courses required}$$

Gable height is measured from inside the horizontal receiving channel to the peak (allowing 1/4" at top and bottom for expansion).

For example, with a 68" gable height, the calculations would be $68 \div 12.5 = 5$ with a remainder of 0.44. This means you would need 5 full courses plus 0.44×12.5 (face exposure of panel) = 5.5" measured from the top edge of the gap on the upper course. This is the visible height for your starter course. The visible height is the vertical dimension of the panel you'll see below the first full row of rounds.

Once you've determined the visible height of the starter course, mark this dimension on a Half-Round Shingle panel. Measure from the top of the gap on the upper course. Draw a cutting line the entire length of panel.

Cut and use the top section, which contains the locks, as your starter course. Cut enough panels to span base of the gable.

Hanging the starter course

To end up with a single "round" centered at the peak of the gable, you must properly locate the first starter panel.

Begin by marking a vertical plumb line from the peak (figure 10).

Then measure and mark the finished height line. In our example, using a starter course with a 5-1/2" visible height, the finished height is 9-3/8".

With your ruler inserted into the pocket of the lower J-channel, mark a line on the substrate equal to the finished height (remember to allow 1/4" for expansion). Repeat at several points along the gable base. Use these marks to strike a horizontal level line that will guide the nailing of the starter course.

The point where the plumb line and the horizontal level line intersect marks the starting point for hanging the first starter course panel (if the first starter panel intersects the plumb line).

Determine whether you will center a "scallop" or a "V" at the starting point. This decision is based on the number of courses required to complete the gable.

The rule of thumb is:

Center an upper scallop if the initial calculations had less than 0.5 courses remaining (0.44 in our example).

Center the gap or "V" of the upper course if more than 0.5 courses remained.

(In our example we require 5.44 courses, so we would center on a scallop.)

More than one panel will probably be required to reach the plumb line. Measure from the plumb line into the pocket receiving channel (leaving 1/4" for expansion) as illustrated in figure 10.

If you require an odd number of courses (i.e. 5 full courses plus starting course), subtract 8" from the distance from the plumb line to the left receiving pocket (remember to allow 1/4" for expansion).

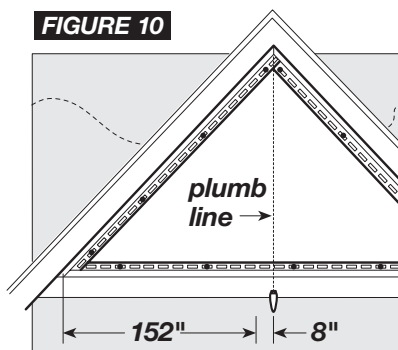

FIGURE 10

If you require an even number of courses (i.e. 6 full courses plus starting course), subtract 18-1/2" from the dimension.

NOTE: The 8" and 18-1/2" dimensions ensure having a full centered scallop at the topmost part of the gable.

For example: If the measurement required to the plumb line (minus 8" for an odd number of full courses) is 152", then $152" \div 32" = 4$ full panels plus 0.75 of one panel or 24" measured from the edge of the texture on the right side.

Create a pattern and trim the first panel (for this example) at 24". Continue to hang the remaining starter course strips, remembering to center nail first. To make a pattern, lock a short piece of siding into the gable starter course (figure 11). Hold a second piece of siding against the J-channel at the slope. Cut along this line using a power saw or tin snips. Use the resulting pattern to cut the panels.

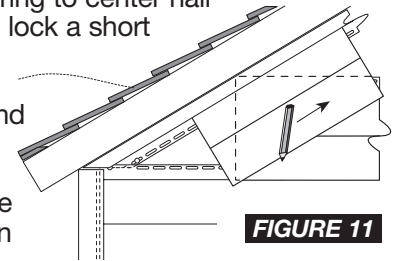

FIGURE 11

Installing first full panel

It is important to stagger the panels as described in this section. The easiest way to determine the length of panel required is to measure from the alignment line on the nail flange of the starter panel to the edge of the roof slope (figure 12).

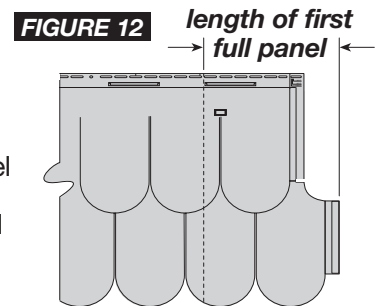

FIGURE 12

Using this measurement, drill a hole centered in the remaining nail flange as described earlier. Lock the first full exposure panel to the starter course after trimming for the roof slope.

After locking the panel in place, center pin the panel.

Lapping remaining panels

The remaining panels to be installed must be lapped in accordance with the current temperature. Repeat this process for the entire course. At the end of each course, trim the panels to the gable angle. Be sure to allow for expansion at the J-channels.

Installing the last round

When you reach the peak, trim the last round to the desired height by removing the locks. Then face nail it to the substrate, using a color-matched finishing nail.

If you have any questions about installing this product, please call us at 800-233-8990.